

FUTRO S720  
FUTRO S920  
ESPRIMO A525-L

---

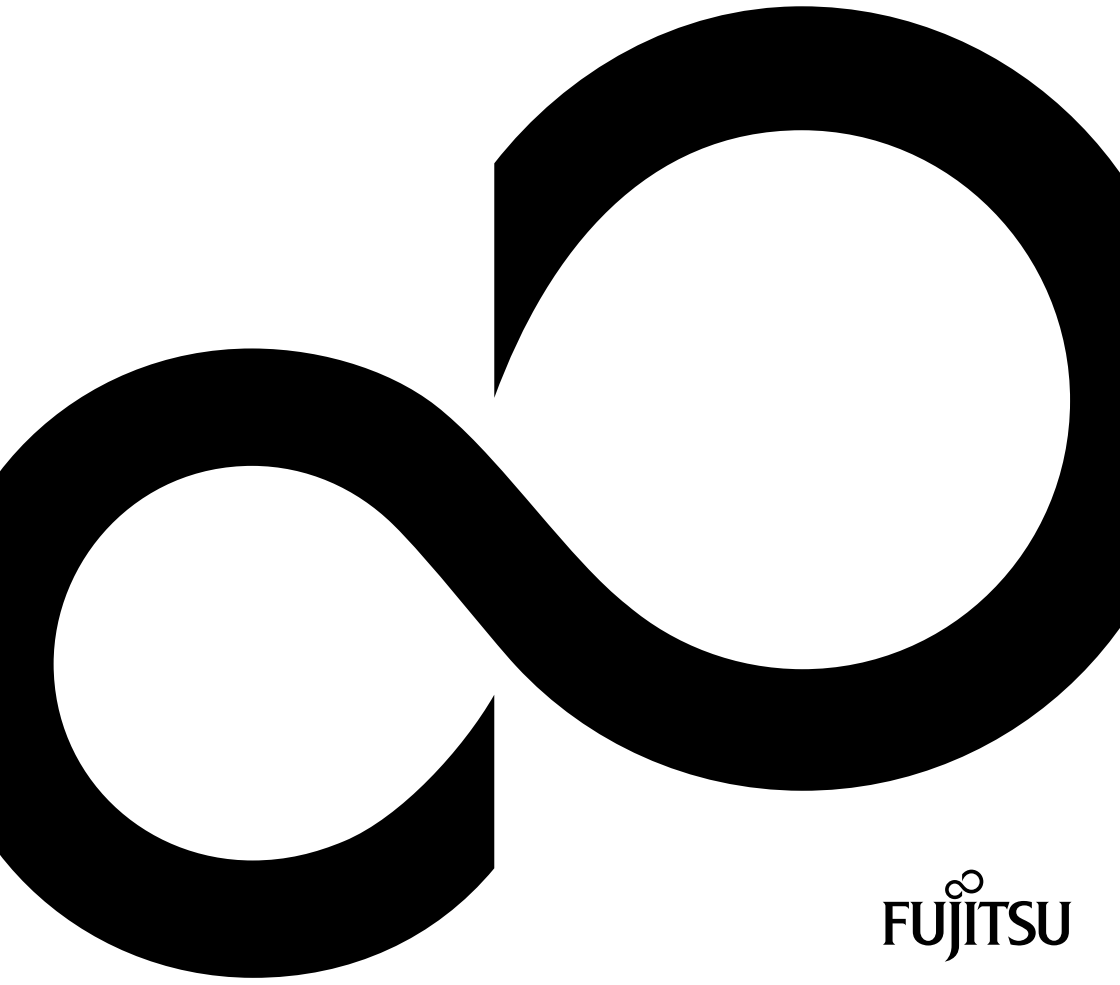

# Thank you for buying an innovative product from Fujitsu.

Latest information about our products, useful tips, updates etc. is available on our website: ["http://www.fujitsu.com/fts/"](http://www.fujitsu.com/fts/)

You can find driver updates at: ["http://support.ts.fujitsu.com/download"](http://support.ts.fujitsu.com/download)

Should you have any technical questions, please contact:

- our Hotline/Service Desk (see Service Desk list or from the Internet at: ["http://support.ts.fujitsu.com/contact/servicedesk"](http://support.ts.fujitsu.com/contact/servicedesk))
- Your sales partner
- Your sales office

We hope you enjoy using your new Fujitsu system!





**Published by / Contact address in the EU**

Fujitsu Technology Solutions GmbH

Mies-van-der-Rohe-Straße 8

80807 Munich, Germany

["http://www.fujitsu.com/fts/"](http://www.fujitsu.com/fts/)

**Copyright**

© Fujitsu Technology Solutions GmbH 2015. All rights reserved.

**Publication Date**

07/2015

Order No.: A26361-K1050-Z321-1-7619, edition 3

# **FUTRO S720 FUTRO S920 ESPRIMO A525-L**

## **Operating Manual**

<b>Validity of the Reference Manual</b>	<b>5</b>
<b>Ports and operating elements</b>	<b>6</b>
<b>Important notes</b>	<b>10</b>
<b>Getting started</b>	<b>16</b>
<b>Operation</b>	<b>25</b>
<b>System expansions</b>	<b>29</b>
<b>Technical data</b>	<b>61</b>
<b>Index</b>	<b>63</b>

**Remarks**

Information on the product description meets the design specifications of Fujitsu and is provided for comparison purposes. Several factors may cause the actual results to differ. Technical data is subject to change without prior notification. Fujitsu rejects any responsibility with regard to technical or editorial mistakes or omissions.

**Trademarks**

Fujitsu, the Fujitsu logo, ESPRIMO and FUTRO are registered trademarks of Fujitsu Limited or its subsidiaries in the United States of America and other countries.

Kensington and Microsaver are registered trademarks of ACCO Brands.

Microsoft and Windows are trademarks or registered trademarks of the Microsoft Corporation in the United States and/or other countries.

Teradici and PCoIP are trademarks of the Teradici Corporation in the United States of America and/or other countries.

All other trademarks specified here are the property of their respective owners.

**Copyright**

No part of this publication may be copied, reproduced or translated without the prior written consent of Fujitsu.

No part of this publication may be saved or transferred by any electronic means without the written approval of Fujitsu.

# Contents

<b>Validity of the Reference Manual</b> .....	<b>5</b>
Notational conventions .....	5
<b>Ports and operating elements</b> .....	<b>6</b>
Front view .....	6
Rear view .....	7
Security functions .....	7
Property and data protection .....	7
Security Lock device .....	8
Securing USB covers (optional) .....	8
<b>Important notes</b> .....	<b>10</b>
Safety notes .....	10
Important notes on preparing your FUTRO S720/S920 or ESPRIMO A525-L for use via the Power over Ethernet module .....	11
Important notes on preparing your FUTRO S920 for use with an external graphics card .....	11
Transporting the device .....	12
Cleaning the device .....	12
Energy saving, disposal and recycling .....	13
FCC Compliance Statement .....	14
FCC Class B Compliance Statement .....	14
CE marking .....	15
<b>Getting started</b> .....	<b>16</b>
Setting up the device .....	16
Vertical operating position .....	16
Horizontal operating position .....	19
Connecting external devices .....	21
Ports on the device .....	21
Connecting a monitor .....	22
Connecting the mouse .....	22
Connecting the keyboard .....	22
Connecting external devices to the serial interface .....	23
Connecting external devices to the USB ports .....	23
Connecting microphone, headphones, line-out and line-in devices .....	24
Connecting the device to the network (LAN) .....	24
Connecting the mains adapter .....	24
<b>Operation</b> .....	<b>25</b>
Switch the device on .....	25
Operating systems and management (device-dependent) .....	25
eLux™ .....	25
Windows Embedded Standard 7 .....	25
Scout Enterprise™ – The management solution for Thin Clients .....	26
Switching off the device .....	27
Activating power saving mode (FUJITSU Thin Client FUTRO only) .....	27
Open BIOS Setup .....	27
PXE system boot .....	27
BIOS Update .....	28
Making system settings .....	28
Executing a system update .....	28
BIOS update using a USB stick .....	28

<b>System expansions</b> .....	<b>29</b>
Overview of optional system components .....	30
Possible combinations for the FUJITSU Thin Client FUTRO S920 .....	30
Information about boards .....	31
Opening the casing .....	32
Adding memory .....	33
Removing memory modules .....	33
Installing a memory module .....	33
Installing and removing the SmartCard reader (FUJITSU Thin Client FUTRO S920 only) .....	34
Installing the SmartCard reader .....	34
Removing the SmartCard reader .....	37
Information about installing and removing a speaker (optional) .....	38
Installing and removing a speaker: FUJITSU Thin Client FUTRO S720 / FUJITSU Thin Client FUTRO S920 .....	39
Installing the loudspeaker .....	39
Removing the loudspeaker .....	41
Installing and removing a speaker: FUJITSU Desktop ESPRIMO A525-L .....	41
Installing a speaker .....	42
Removing a speaker .....	48
Installing and removing a Power over Ethernet module (optional) .....	53
Installing the Power over Ethernet module .....	53
Removing the Power over Ethernet module .....	55
Installing and removing a board .....	56
Installing the board .....	56
Removing the board .....	58
Replacing the lithium battery .....	59
Closing the casing .....	60
<b>Technical data</b> .....	<b>61</b>
FUTRO/ESPRIMO .....	61
AC adapter .....	62
<b>Index</b> .....	<b>63</b>







# Validity of the Reference Manual

This Reference Manual is valid for the following systems:

- FUJITSU Thin Client FUTRO S720
- FUJITSU Thin Client FUTRO S920
- FUJITSU Desktop ESPRIMO A525-L

## Notational conventions

	Pay particular attention to text marked with this symbol. Failure to observe these warnings could pose a risk to health, damage the device or lead to loss of data. The warranty will be invalidated if the device becomes defective through failure to observe these warnings.
	Indicates important information for the proper use of the device.
	Indicates an activity that must be performed
	Indicates a result
<b>This font</b>	indicates data entered using the keyboard in a program dialogue or at the command line, e.g. your password ( <b>Name123</b> ) or a command used to start a program ( <b>start.exe</b> )
This font	indicates information that is displayed on the screen by a program, e.g.: Installation is complete.
<i>This font</i>	indicates <ul style="list-style-type: none"> <li>• terms and texts used in a software interface, e.g.: Click on <i>Save</i></li> <li>• names of programs or files, e.g. <i>Windows</i> or <i>setup.exe</i>.</li> </ul>
"This font"	indicates <ul style="list-style-type: none"> <li>• cross-references to another section, e.g. "Safety information"</li> <li>• cross-references to an external source, e.g. a web address: For more information, go to "<a href="http://www.fujitsu.com/fts">http://www.fujitsu.com/fts</a>"</li> <li>• Names of CDs, DVDs and titles or designations for other materials, e.g.: "CD/DVD Drivers &amp; Utilities" or "Safety/Regulations" manual</li> </ul>
<b>Key</b>	indicates a key on the keyboard, e.g.: <b>F10</b>
<b>This font</b>	indicates terms and texts that are emphasised or highlighted, e.g.: <b>Do not switch off the device</b>

# Ports and operating elements

This chapter presents the individual hardware components of your device. This will provide you with an overview of the ports and operating elements on the device. Please familiarise yourself with these components before starting to work with your device.

## Front view

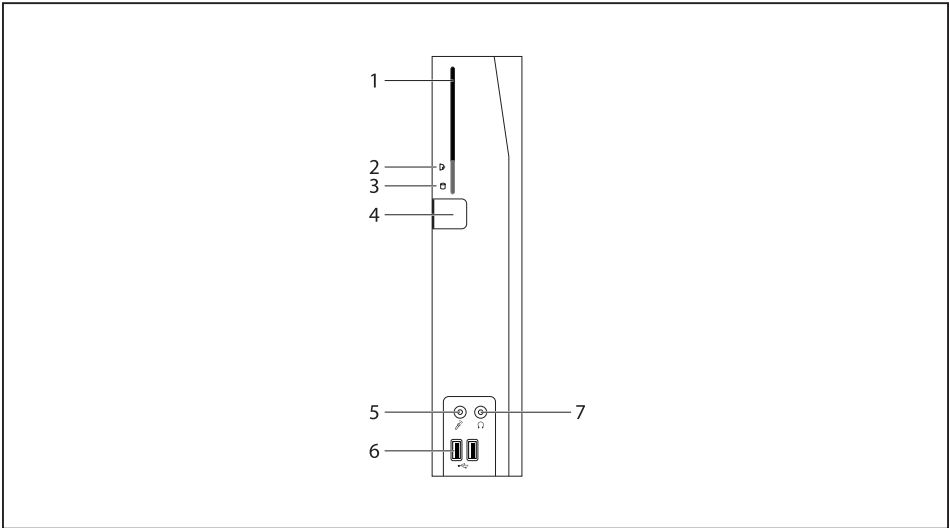

1 = SmartCard reader (FUJITSU Thin Client  
FUTRO S920 only, optional)

2 = Indicator for SmartCard reader

3 = Flash memory or hard disk access

4 = ON/OFF switch

5 = Microphone jack

6 = USB ports (Universal Serial Bus)

7 = Headphones port, audio output (Line Out)

# Rear view

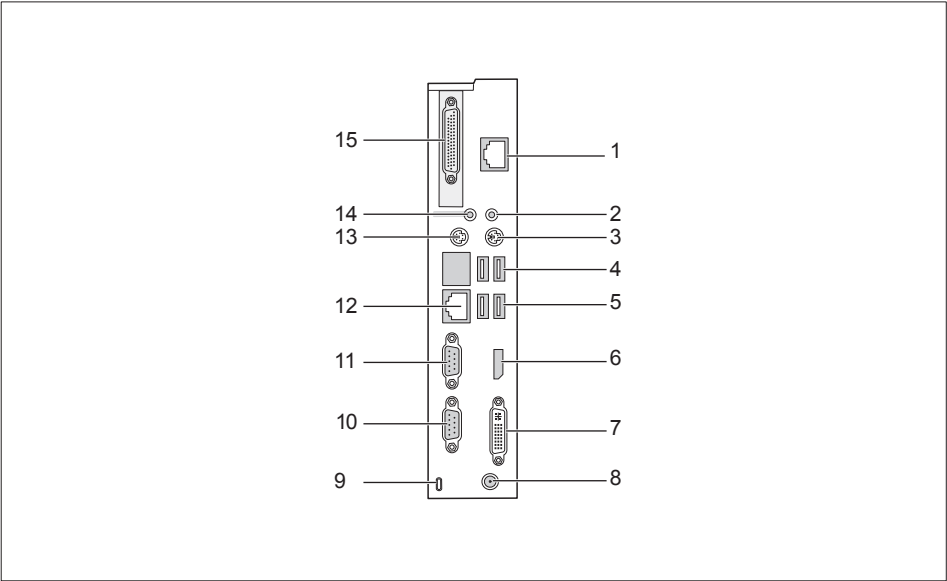

- 1 = Socket for Power over Ethernet module (optional)
- 2 = Audio output (Line Out)
- 3 = PS/2 keyboard port
- 4 = USB ports
- 5 = USB ports
- 6 = DisplayPort
- 7 = DVI-I monitor port
- 8 = DC input jack (DC IN)

- 9 = Security Lock device
- 10 = Serial port
- 11 = Serial port (only for FUJITSU Thin Client FUTRO S920)
- 12 = RJ45 socket (Local Area Network)
- 13 = PS/2 mouse port
- 14 = Audio input (Line In)
- 15 = PCI/PCIe port (FUJITSU Thin Client FUTRO S920 only, optional)

## Security functions

### Property and data protection

Software functions and mechanical locking offer a broad range of functions for protecting your device and your personal data from unauthorised access. You can also combine these functions.

## Security Lock device

Using the Security Lock device and the Kensington Lock cable (steel cable, accessory) you can protect your device against theft. Please consult the manual for your Security Lock.

Your device has a Security Lock device on the rear side.

If you are using the VESA sub-adapter, first connect the Kensington Lock Cable to the Security Lock device and then mount your device on the VESA sub-adapter. You can find more information in the manual for your FUJITSU FUTRO S monitor carrier.



When using the Security Lock device, opening of the casing is also prevented.

## Securing USB covers (optional)

To prevent use of the USB ports, you can attach optional USB covers to the USB ports on the front and rear side of the device.



Please note that USB covers, once fitted, cannot be removed again!

Ensure that you fit the USB covers the right way round.

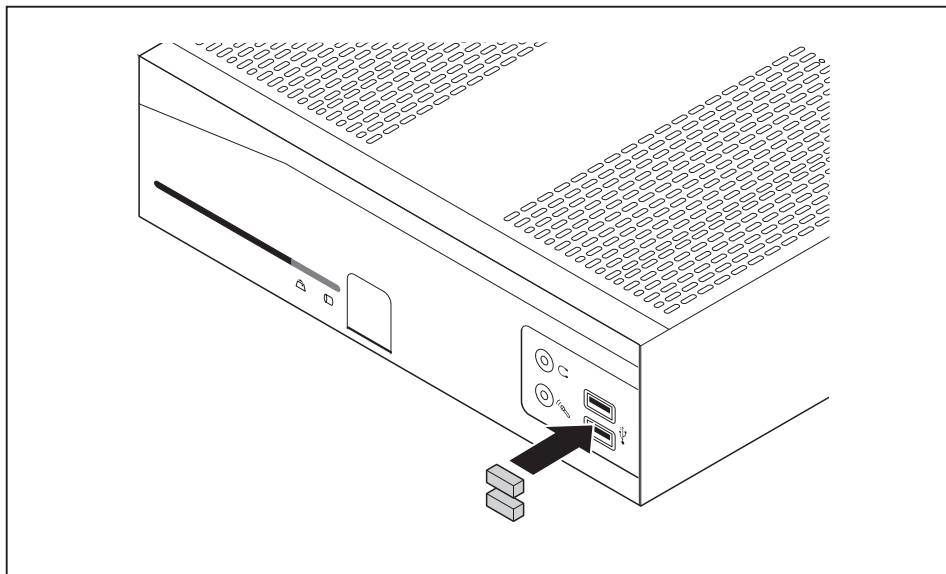

- ▶ Insert the USB covers in the USB ports on the front of the device and push the USB covers in firmly.

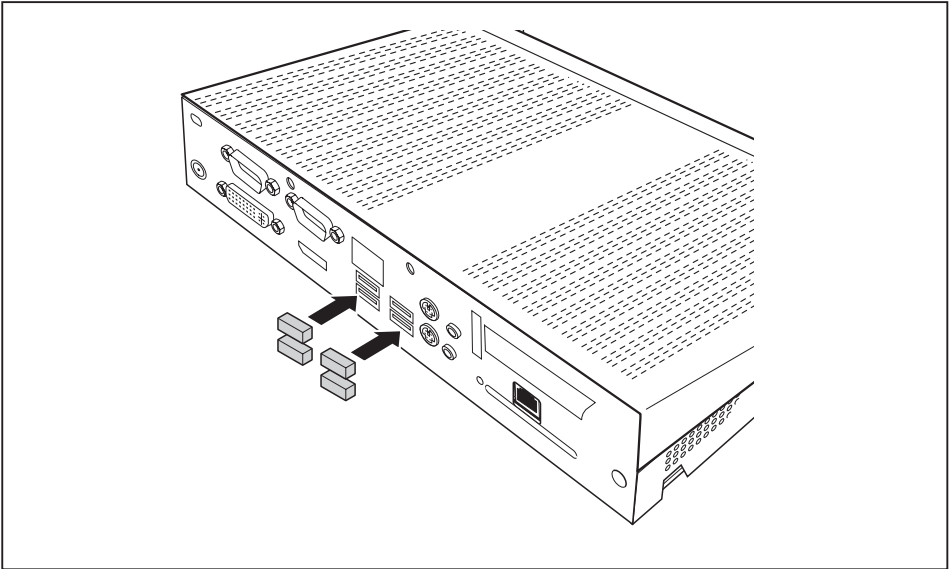

- ▶ Insert the USB covers in the USB ports on the rear side of the device and push the USB covers in firmly.



In the *BIOS Setup*, under *Advanced - USB Port Security*, you can also deactivate the USB ports, in order to limit the use of USB devices.

# Important notes

In this chapter you will find information regarding safety which it is essential to take note of when working with your device.

## Safety notes



Please follow the safety notes provided in the "Safety/Regulations" manual as well as the safety notes given below.

When installing and operating the device, please observe the notes on ambient conditions in "[Technical data](#)", [Page 61](#) and the instructions in "[Getting started](#)", [Page 16](#).

Replace the lithium battery on the mainboard exactly in accordance with the instructions in the "[Replacing the lithium battery](#)", [Page 59](#) chapter.

Caution, components in the system can get very hot.

The activities described in these instructions must always be performed with the greatest care.

Repairs to the device must only be carried out by qualified technicians. Incorrect repairs could put the user at great risk (electric shock, hazardous energy emissions, risk of fire) or cause serious damage to the equipment.

Operate the device only with the casing closed.



Power cable and mains adapter:

The supplied power cable conforms to the requirements of the country in which you purchased your device. Make sure that the power cable is approved for use in the country in which you intend to use it.

The mains adapter's power cable should only be connected to a mains socket if the device is connected.

Do not use the mains adapter for other devices.

Use only the mains adapter which is intended for use with the device, see chapter "[Technical data](#)", [Page 61](#).

Make sure that the rated current of the mains adapter is not higher than that of the power system to which you connect the mains adapter.

ON/OFF switches do not disconnect the device from the mains voltage. To completely disconnect the mains voltage, remove the power plug from the power socket.

## Important notes on preparing your FUTRO S720/S920 or ESPRIMO A525-L for use via the Power over Ethernet module

With the aid of the Power over Ethernet module, you can operate the FUTRO S720/S920 or the ESPRIMO A525-L over the LAN without any additional power connection. You will need a suitable network infrastructure for this.

To operate the FUTRO S720/S920 or the ESPRIMO A525-L via the Power over Ethernet module, midspan devices conforming to IEEE 802.3at and shielded CAT 5 network cable or higher quality cable are required. Endsapn devices will only be supported in conjunction with a hardware classification. Fujitsu recommends the use of the following midspan devices:

- 1 port midspan from Microsemi PD-9501G: S26361-F1744-L10
- 12 port midspan from Microsemi PD-9512G: S26361-F1744-L20

Because of the limited power output, not all hardware configuration levels are possible for operating the FUTRO S720/S920 or the ESPRIMO A525-L via the Power over Ethernet module. The following hardware configurations are possible:

Internal memory expansion	according to Configurator
mSATA module (FUTRO) / HDD (ESPRIMO)	according to Configurator
SmartCard reader	internal SmartCard reader
Speaker	internal speaker
WLAN	internal WLAN module according to Configurator
PCI/PCIe cards or extra interfaces	none

Depending on the system utilisation, occupancy of external interfaces (excluding the keyboard, screen, microphone and headset) may cause overloading of the Power over Ethernet module. In order to support the largest possible occupancy of interfaces, if an overload occurs the performance of the system is lowered by a reduction in the CPU frequency. If the CPU frequency is permanently reduced, the occupancy of the external interfaces must be checked and reduced accordingly to prevent damage to the Power over Ethernet module or the midspan. Alternatively, the system can also be connected via a suitable AC adapter (see note in this Operating Manual). The system must be switched off before the AC adapter is connected.

If you are perhaps retrofitting a FUTRO/ESPRIMO with a Power over Ethernet module, please pay attention to the maximum possible expansion. If PCI/PCIe expansion cards are installed (FUTRO S920), these must be removed, otherwise the Power over Ethernet module or the midspan may be overloaded and switched off automatically.

## Important notes on preparing your FUTRO S920 for use with an external graphics card

The FUTRO S920 may in addition be fitted with a graphics card. Only specially approved graphics cards are allowed to be used. If a graphics card is retrofitted in the FUTRO S920, it is important to note that a 65W AC adapter is needed for operation. The FUTRO S920 without a graphics card is only supplied from the factory with a 40W AC adapter as standard.

## Transporting the device



Transport all parts separately in their original packaging or in a packaging which protects them from knocks and jolts, to the new site.

Do not unpack them until all transportation manoeuvres are completed.

If the device is brought from a cold environment into the room where it will be used, condensation may occur. Before operating the device, wait until it is absolutely dry and has reached approximately the same temperature as the installation site.

## Cleaning the device



Turn off all power and equipment switches and disconnect the power plug from the mains outlet.

Do not clean any interior parts yourself, leave this job to a service technician.

Do not use any cleaning agents that contain abrasives or may corrode plastic (alcohol, thinner or acetone).

Never clean the device with water! Water entering into the device could present a serious risk to users (e.g. electric shock).

Ensure that no liquid enters the system.

The surface can be cleaned with a dry cloth. If particularly dirty, use a cloth that has been moistened in mild domestic detergent and then carefully wrung out.

Use disinfectant wipes to clean the keyboard and the mouse.



## Energy saving, disposal and recycling

You can find information on these subjects in chapter ["Activating power saving mode \(FUJITSU Thin Client FUTRO only\)", Page 27](#), on the Recovery DVD or on our website ("<http://www.fujitsu.com/fts/about/fts/environment-care/>").

### **The following sections apply to the FUJITSU Thin Client FUTRO only:**

Information on the "Ecodesign directive": Regulation 1275/2008, based on the EU Ecodesign Directive (2009/125/EU), defines requirements for the power consumption of electrical and electronic domestic and office devices in stand-by and off mode.

In general, all FUTRO thin client products have been developed for energy-efficient operation and low stand-by losses. Due to customer-specific and operating system-specific requirements, which are the priority for optimal operation, some system settings are necessary which deviate from the above-mentioned directive.

For administrative purposes, such as remote maintenance of systems, the "Wake-on-LAN" (WoL) function is indispensable for our customers and is therefore a default setting. When the WoL functions are active, the maximum permissible power draw can be exceeded slightly in OFF mode. By deactivating the WoL function, it is possible to comply with the legal requirements. Please see chapter ["Activating power saving mode \(FUJITSU Thin Client FUTRO only\)", Page 27](#) for the procedure.

The energy saving mode (ACPI S4 Save-to-disk), which is familiar from many current mobile and desktop systems, is not available in the embedded operating systems for technical reasons. Therefore, it is not possible to switch devices with this operating system automatically into Off mode.

The operating system of a thin client is stored on a flash memory with optimised size and is provided with write protection after configuration has been completed by the customer. This prevents data security from being put at risk through frequent writing to a flash memory, such as when updating the *Swapfiles* in the operating system or through other applications. Every flash memory permits only a limited number of write cycles. Both the activated write protection and the available, limited flash memory capacity rule out the possibility of activating energy saving mode (ACPI S4).

## FCC Compliance Statement

If the device complies with the FCC regulations, the FCC sign can be found on the type rating plate.

### FCC Class B Compliance Statement

#### DOC (INDUSTRY CANADA) NOTICES

##### Notice to Users of Radios and Television:

This class B digital apparatus complies with Canadian ICES-003.

The following statement applies to the products covered in this manual, unless otherwise specified herein. The statement for other products will appear in the accompanying documentation.

##### NOTE:

This equipment has been tested and found to comply with the limits for a "Class B" digital device, pursuant to Part 15 of the FCC rules and meets all requirements of the Canadian Interference-Causing Equipment Standard ICES-003 for digital apparatus. These limits are designed to provide reasonable protection against harmful interference in a residential installation. This equipment generates, uses and can radiate radio frequency energy and, if not installed and used in strict accordance with the instructions, may cause harmful interference to radio communications. However, there is no guarantee that interference will not occur in a particular installation. If this equipment does cause harmful interference to radio or television reception, which can be determined by turning the equipment off and on, the user is encouraged to try to correct the interference by one or more of the following measures:

- Reorient or relocate the receiving antenna.
- Increase the separation between equipment and the receiver.
- Connect the equipment into an outlet on a circuit different from that to which the receiver is connected.
- Consult the dealer or an experienced radio/TV technician for help.

Fujitsu is not responsible for any radio or television interference caused by unauthorized modifications of this equipment or the substitution or attachment of connecting cables and equipment other than those specified by Fujitsu. The correction of interferences caused by such unauthorized modification, substitution or attachment will be the responsibility of the user.

The use of shielded I/O cables is required when connecting this equipment to any and all optional peripheral or host devices. Failure to do so may violate FCC and ICES rules.

### FCC Radiation Exposure Statement

This equipment complies with FCC radiation exposure limits set forth for an uncontrolled environment.

The transmitters in this device must not be co-located or operated in conjunction with any other antenna or transmitter.

To prevent radio interference to the licensed service, this device is intended to be operated indoors and away from windows to provide maximum shielding. Equipment (or its transmit antenna) that is installed outdoors is subject to licensing.

Users are not authorized to modify this product. Any modifications invalidate the warranty.

This equipment may not be modified, altered, or changed in any way without signed written permission from Fujitsu. Unauthorized modification will void the equipment authorization from the FCC and Industry Canada and the warranty.

## CE marking

The shipped version of this device meets the requirements of EU directives 2004/108/EC "Electromagnetic compatibility", 2006/95/EC "Low voltage directive", 2011/65/EU "RoHS directive" and 2009/125/EC "Ecodesign directive".

For this purpose, please also note the special information concerning the "Ecodesign directive" for the FUTRO systems (see ["Energy saving, disposal and recycling", Page 13](#)).

This device may be used in the following countries:

Belgium	Bulgaria	Denmark	Germany
Estonia	Finland	France	Greece
United Kingdom	Rep. of Ireland	Iceland	Italy
Croatia	Latvia	Liechtenstein	Lithuania
Luxembourg	Malta	Netherlands	Norway
Austria	Poland	Portugal	Romania
Sweden	Switzerland	Slovakia	Slovenia
Spain	Turkey	Czech Republic	Hungary
Cyprus			

Please contact the appropriate government office in the particular country for current information on possible operating restrictions. If your country is not included in the list, please contact the relevant supervisory authority to find out whether the use of this product is permitted in your country.

# Getting started



Please observe the safety information in the "[Important notes](#)", [Page 10](#) chapter.

## Setting up the device



In order to ensure that the casing is sufficiently ventilated and to prevent overheating, the device must only be operated with the base foot attached.

If the device is to be built-in, adequate ventilation must be assured.



Fit the base feet for horizontal or vertical operation (see "[Vertical operating position](#)", [Page 16](#) and "[Horizontal operating position](#)", [Page 19](#)).

## Vertical operating position



If you wish to operate the device in the vertical operating position, use the two feet supplied for vertical operation.

Only mount the feet on the device side shown in the diagrams.

If connecting many cables to the device, ensure that the device is in a stable position, in order to prevent it from toppling over.

Proceed as follows to prepare the device for the vertical operating position:

- ▶ Disconnect the cables if required.
- ▶ Lay the device on its top (narrow side) as shown, on a stable, flat and clean surface.

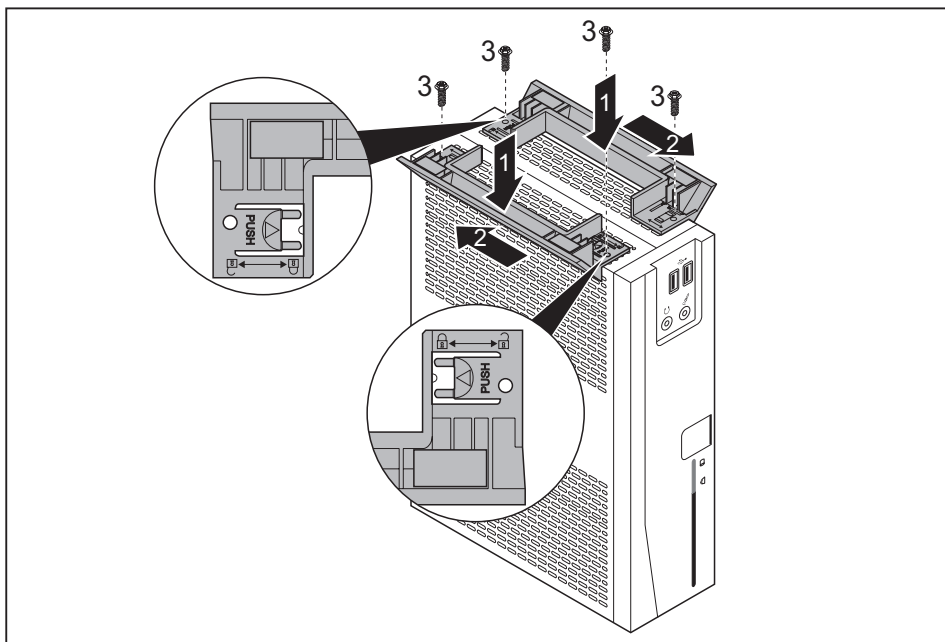

- ▶ Hook the feet into each of the openings provided for this in the casing (1).

**i**

There are lock symbols on the foot, indicating the direction in which the foot must be pushed during installation or removal:

- Secure and lock the foot = push to the left (closed lock)
- Unlock and release the foot = push to the right (open lock)

- ▶ Repeat for each foot: Push the outer elements of the foot evenly onto the casing using both hands, keep the "Push" button pressed (see magnifier) and push the foot in the direction of the arrow (2) until it is heard to engage.

**i**

To protect your device against unauthorised removal of the feet, the feet can also be secured with two screws each, of type M2.5x5 mm. These are not included in the delivery scope.

- ▶ Secure the feet with the screws (3).

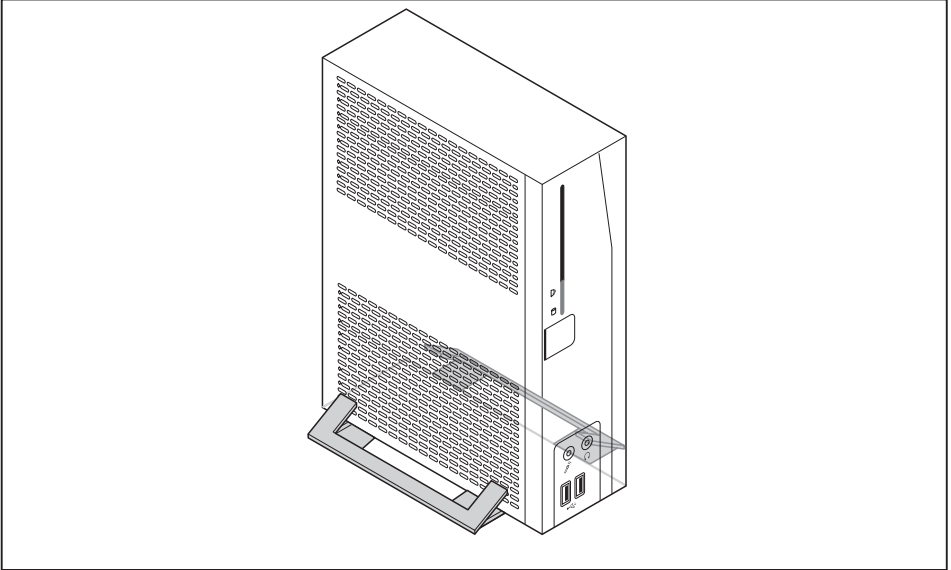

- ▶ Stand the device on the feet.
- ▶ If necessary, reconnect any cables that were previously disconnected.

## Horizontal operating position



If you wish to operate the device in the horizontal operating position, use the two feet supplied for horizontal operation.

Only mount the feet on the device side shown in the diagrams.

Proceed as follows to prepare the device for the horizontal operating position:

- ▶ Disconnect the cables if required.
- ▶ Lay the device on its right side as shown, on a stable, flat and clean surface.

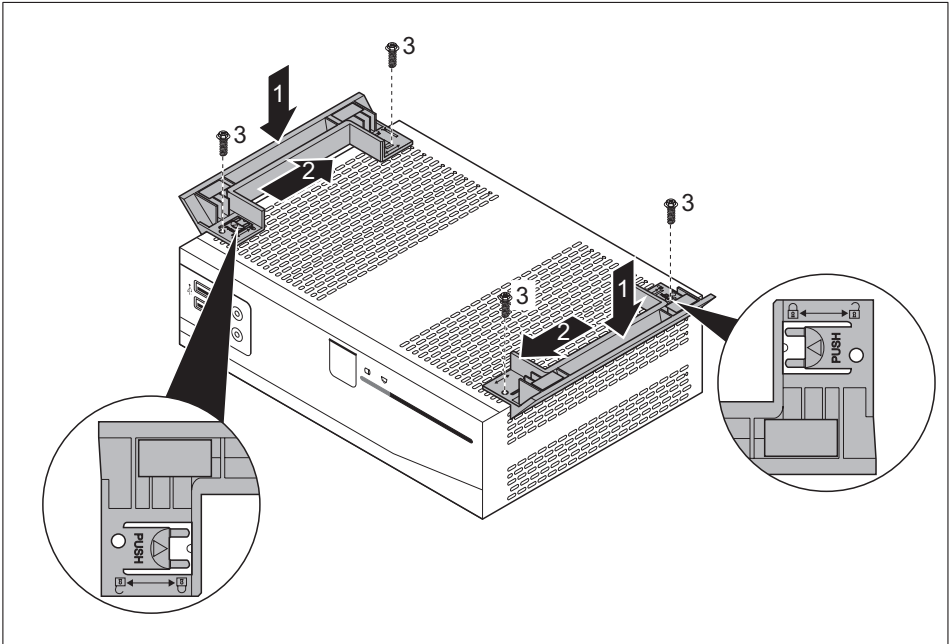

- ▶ Hook the feet into each of the openings provided for this in the casing (1).



There are lock symbols on the foot, indicating the direction in which the foot must be pushed during installation or removal:

- Secure and lock the foot = push to the left (closed lock)
- Unlock and release the foot = push to the right (open lock)

- ▶ Repeat for each foot: Keep the "Push" button pressed down (see magnifier) and push the foot in the direction of the arrow (2) until it is heard to engage.



To protect your device against unauthorised removal of the feet, the feet can also be secured with two screws each, of type M2.5x5 mm. These are not included in the delivery scope.

- ▶ Secure the feet with the screws (3).

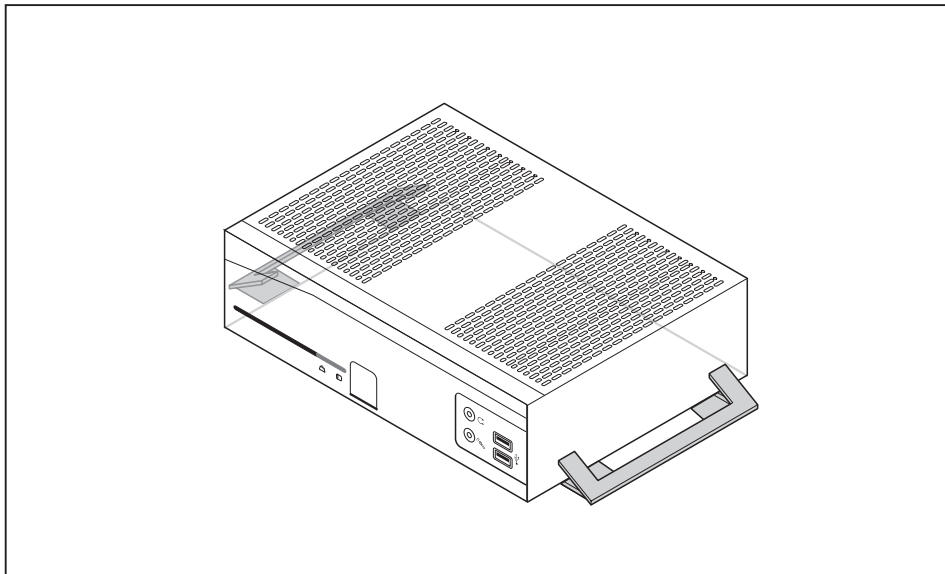

- ▶ Stand the device on the feet.
- ▶ If necessary, reconnect any cables that were previously disconnected.



## Connecting external devices



Read the documentation on the external device before connecting it.

To ensure that your device works properly, use either only the supplied connection cable or only other connection cables of equivalent quality.

With the exception of USB devices, always remove all power plugs before connecting external devices!

Do not connect or disconnect cables during a thunderstorm.

Always take hold of the actual plug. Never unplug a cable by pulling the cable itself.

## Ports on the device

The ports are located on the front and rear side of the device. The ports available on your device depend on the configuration level you have selected. The standard ports are marked with the symbols shown below (or similar). Detailed information on the location of the ports is provided in the manual for the mainboard.



Headphones, black (front of device)



Microphone port, black (front of device)



Audio output (Line Out), light green



Audio input (Line In), light blue



Serial port, turquoise



DVI-I monitor port, white



USB - Universal Serial Bus:

- blue: USB 3.0, front of device
- black: USB 2.0, rear of device



RJ45-LAN port



PS/2 mouse port, green



PS/2 keyboard port, purple

**DP**

DisplayPort



Some of the connected devices require special software (e.g. drivers) (refer to the documentation for the connected device and operating system).

### Connecting a monitor

- ▶ Follow the instructions contained in the monitor manual to prepare the monitor for operation (e.g. connecting cables).
- ▶ Connect the data cable to the required monitor port on your device.
- ▶ Plug the monitor power cable into the grounded mains outlet.

### Connecting the mouse

You can connect a USB mouse or a PS/2 mouse to your device.

#### Connecting a USB mouse

- ▶ Connect the USB mouse to one of the USB ports on the device.

#### Connecting a PS/2 mouse



The PS/2 mouse is only detected by the device if you connect the mouse when the device is switched off and then switch the device on again.

- ▶ Connect the PS/2 mouse to the PS/2 mouse port of the device.
- ▶ Switch your device on again.

### Connecting the keyboard

You can connect a USB keyboard or a PS/2 keyboard to your device.

#### Connecting a USB keyboard

Use the supplied keyboard cable only.

- ▶ Insert the flat rectangular USB plug of the keyboard cable into one of the device's USB ports.

#### Connecting a PS/2 keyboard

Use the supplied keyboard cable only.



The PS/2 keyboard is only detected by the device if you connect the keyboard when the device is switched off and then switch the device on again.

- ▶ Switch your device off.
- ▶ Plug the round plug of the keyboard cable into the keyboard port on the device.
- ▶ Switch your device on again.

## Connecting external devices to the serial interface

External devices can be connected to the serial interface (e.g. a printer or modem).

- ▶ Connect the data cable to the external device.
- ▶ Connect the data cable to the corresponding serial interface.
- ↳ For an exact description of how to connect external devices to the corresponding port, please see the external device documentation.

### Port settings



You can change the port settings (e.g. address, interrupt) in the *BIOS Setup*.

### Device drivers



The devices connected to the serial interface require drivers. Your operating system already includes many drivers. If the required drive is missing, install it. The latest drivers are usually available on the Internet or will be supplied on a data carrier.

## Connecting external devices to the USB ports

You can connect a wide range of external devices to the USB ports (e.g. printer, scanner, modem or keyboard).



USB devices are hot-pluggable. This means you can connect and disconnect USB cables while your device is switched on.

Additional information can be found in the documentation for the USB devices.

- ▶ Connect the data cable to the external device.
- ▶ Connect the data cable to one of the USB ports on your device.

### Device drivers



The external USB devices you connect to the USB ports usually require no driver of their own, as the required software is already included in the operating system. If the device requires separate software, please note the information in the manufacturer's manual.

To ensure the transmission capacity of USB 2.0, the cable from the external USB device to the USB port of your device must not be longer than 3 m / 118.11 inches.

## Connecting microphone, headphones, line-out and line-in devices

- ▶ Connect the microphone to the microphone port.
- ▶ Connect the headphones to the headphones port.
- ▶ Connect line-out devices to the audio output.
- ▶ Connect the external line-in devices to the audio input.

## Connecting the device to the network (LAN)

- ▶ Connect the 10/100/1000 Base T network cable to the RJ45 LAN port.

## Connecting the mains adapter



Observe the safety notes in the enclosed "Safety/Regulations" manual.

The supplied power cable conforms to the requirements of the country in which you purchased your device. Make sure that the power cable is approved for use in the country in which you intend to use it.

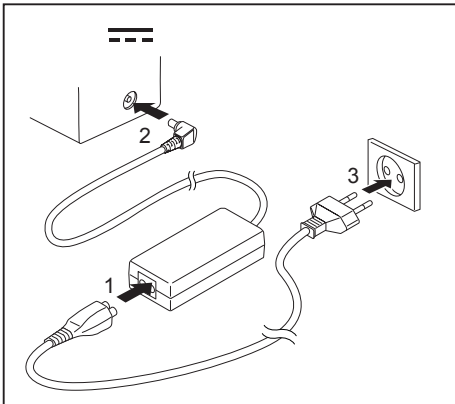

- ▶ Connect the mains cable (1) to the mains adapter.
- ▶ Connect the mains adapter cable (2) to the DC jack (DC IN) of the device.
- ▶ Plug the mains cable (3) into a mains socket.

---

# Operation

## Switch the device on

- ▶ If necessary, switch the monitor on (see the operating manual for the monitor).
- ▶ Press the ON/OFF switch on the front of the device.
- ↳ The power indicator lights up and the device starts.

## Operating systems and management (device-dependent)

Depending on the configuration level, your device is fitted with one of the following operating systems:

- eLux™
- Windows Embedded Standard 7

You device can be managed with the *Scout Enterprise™* management solution.

### eLux™

The eLux™ Thin Client operating system is based on Linux and is protected against viruses and malware by the write-protected file system.

It has a lean and modular structure, and thus has low demands on the hardware. It enables access to the server via the integrated Citrix and Microsoft clients as well as the optional VMware client. It has a user-friendly licence model, with the possibility of transferring licences to new devices.



Updates for eLux™ can be found on the Fujitsu support pages or on the Internet at "[www.myelux.com](http://www.myelux.com)".

For more information on eLux™, go to "<http://www.unicon-software.com/produkte/elux/>".

### Windows Embedded Standard 7

Windows Embedded Standard 7 from Fujitsu offers optimal integration in Scout or SCCM. It enables modular updates with Scout and thus saves network bandwidth.

Updates for Windows Embedded Standard 7 can be found on the Internet at "<http://support.ts.fujitsu.com/>".

## Scout Enterprise™ – The management solution for Thin Clients

### Basic functionalities

- Multi-administrator policy
- Simple scalability and high availability
- Optimal support of complex organisations

### Asset management functions

- Display of serial number and connected monitors
- Illustration of update history
- Flexible licence management
- Display of device, hardware and network information
- Display of installed or connected components, such as mainboard, memory, display adapters, monitors and USB devices

### User-friendliness and handling

- Simple and intuitive operation
- Automatic updates of eLux™ packages and Windows Embedded Standard 7 packages
- Complete audit reporting

### Help Desk support

- Support of Wake-On-LAN and Remote Power On/Off
- Mirroring of desktops, encrypted and audit-proof
- Extensive diagnostic information



For more information on Scout Enterprise™, go to ["http://www.unicon-software.com/produkte/scofut-enterprise/"](http://www.unicon-software.com/produkte/scofut-enterprise/).

More information and manuals are available on the Internet at ["http://www.unicon-software.com/udocs"](http://www.unicon-software.com/udocs).

## Switching off the device

- ▶ Shut down the operating system in the proper way. In Windows: from the *Start* menu select the *Shut Down* option.
- ▶ If the operating system does not automatically switch the device into energy-saving mode or switch it off, press the ON/OFF switch. Warning, this could lead to a loss of data!
- ↳ If the device is switched off, it consumes a minimum of energy.



The ON/OFF switch does not disconnect the device from the mains voltage. To completely disconnect the mains voltage, remove the power plug from the power socket.

- ▶ If necessary, switch the monitor off (see the operating manual for the monitor).

## Activating power saving mode (FUJITSU Thin Client FUTRO only)

Due to customer requirements and requirements of the operating system, the "Wake-on-LAN" (WoL) function is switched on by default. With the WoL function, the power draw in OFF mode increases slightly.

To meet the requirements of EC regulation 1275/2008 regarding the implementation of the Ecodesign directive (2009/125/EC), the default WoL setting must be changed as follows:

- ▶ To start the *BIOS Setup Utility* after system boot, press function key **F2** or the **Del** key.
- ▶ In the *Power* sub-menu, select the *Low Power Soft Off* setting and switch it to *enabled*.
- ▶ To save the setting and exit the *BIOS Setup Utility*, press function key **F4**.
- ↳ After making this change, the system will achieve the lowest energy saving mode during shut-down.  
In this status, the "Wake-on-LAN" function can no longer be used.

## Open BIOS Setup

- ▶ When the system starts, press the **F2** key (several times if necessary).
- ↳ *BIOS Setup* will be started. Select one of the tabs to access other setting options in *BIOS Setup*.

## PXE system boot

- ▶ Switch the device on with the ON/OFF switch.
- ▶ When starting the system, press the **F12** key several times.
- ↳ The boot menu is displayed.
- ▶ Select the desired boot option.

## BIOS Update

### When should a BIOS update be performed?

Fujitsu Technology Solutions makes new BIOS versions available to ensure compatibility with new operating systems, new software or new hardware. In addition, new BIOS functions can be integrated.

A BIOS update should also always be performed if there is a problem that cannot be solved using new drivers or new software.

### Where can I obtain BIOS updates?

You can find the BIOS updates on the Internet at ["http://support.ts.fujitsu.com/"](http://support.ts.fujitsu.com/).

## Making system settings

Make the system settings as described in the documentation for your operating system.

## Executing a system update

There are two ways of updating your system software:

- via the Unicon Product Scout
- via an external USB data carrier

For information on the system update, see the documentation on your operating system.

## BIOS update using a USB stick

- ▶ Make sure you have a bootable USB stick available.
- ▶ Download the "Admin package – Compressed Flash Files" for bootable USB sticks from our website to your PC.
- ▶ Unzip the *ZIP file* and copy the files onto your bootable USB stick.
- ▶ Reboot the PC and press and hold the **F12** key to start the Boot menu.
- ▶ Select the USB stick as the boot device.
- ▶ Boot from the USB stick and start *DosFlash.BAT*.
- ▶ Follow the on-screen instructions.



# System expansions



Repairs to the device must only be performed by qualified technicians. Incorrect repairs may greatly endanger the user (electric shock, fire risk) and will invalidate your warranty.

After consulting the Hotline/Help Desk, you may remove and install the components described in this manual yourself.



As the device has to be shut down in order to install/deinstall system hardware components, it is a good idea to print out the relevant sections of this chapter beforehand.

A component holder is required for the installation of certain components in the FUJITSU Thin Client FUTRO S920. Depending on the device variant, the holder may already be pre-installed in the factory. If the component holder is not pre-installed, follow the installation instructions in the enclosed supplement "System expansions for FUJITSU Thin Client FUTRO S900 / S920".

The following illustrations may differ slightly from your device, depending on its configuration level.

If further documentation was delivered with your device, please also read this through carefully.

In addition, before removing or installing system components, please pay attention to the following:



The device must be switched off when installing/removing the system expansions and may not be in energy-saving mode.

Remove the power plug before opening the device.

Be careful that no wires become trapped when removing or installing components.

When installing components that become very hot, make sure that the maximum permissible temperature of the components in operation is not exceeded.



An update of the BIOS may be required for a system expansion or hardware upgrade. Further information can be found in the BIOS help section or if necessary in the Technical Manual for the mainboard.

## Overview of optional system components

The following optional system components can be installed in the various device types:

System component	FUJITSU Thin Client FUTRO S720	FUJITSU Thin Client FUTRO S920	FUJITSU Desktop ESPRIMO A525-L
Hard disk	—	—	Installed when delivered
SmartCard reader	optional	optional	—
Speaker	optional	optional	optional
Power over Ethernet module	optional	optional	optional
Third serial port	—	optional*	—
Parallel port	—	optional*	—
PCIe dual serial card	—	optional*	—
PCIe ATI V3900	—	optional*	—

\* In each case, only one of these components can be simultaneously installed in a system.

## Possible combinations for the FUJITSU Thin Client FUTRO S920

For the FUJITSU Thin Client FUTRO S920, the following system components can be combined together:

System component	Smart Card reader	Speaker	Power over Ethernet module	Third serial port	Parallel port	PCIe dual serial card	PCIe ATI V3900
Smart Card reader	—	✓	✓	✓	✓	✓	✓
Speaker	✓	—	✓	✓	✓	✓	✓
Power over Ethernet module	✓	✓	—	—	—	—	—
Third serial port	✓	✓	—	—	—	—	—
Parallel port	✓	✓	—	—	—	—	—
PCIe dual serial card	✓	✓	—	—	—	—	—
PCIe ATI V3900	✓	✓	—	—	—	—	—

## Information about boards

Take care with the locking mechanisms (catches and centring pins) when you are replacing boards or components on boards.

Note that some components on the mainboard may be very hot if the device was in use shortly before the casing was removed.

To prevent damage to the board or the components and conductors on it, please take care when you insert or remove boards. Make sure expansion boards are inserted straightly.

Never use sharp objects (screwdrivers) for leverage.



Boards with electrostatic sensitive devices (ESD) are identifiable by the label shown.

When handling boards fitted with ESDs, you must always observe the following points:

- You must always discharge static build up (e.g. by touching a grounded object) before working.
- The equipment and tools you use must be free of static charges.
- Only touch or hold the boards by the edge or, if present, at the areas marked green (Touch Points).
- Never touch pins or conductors on boards fitted with ESDs.

## Opening the casing

- ▶ Switch the device off. The device must not be in power-saving mode.



Please observe the safety information in "[Important notes](#)", [Page 10](#).

Disconnect the mains plug from the mains outlet.

Only insert the power plug after you have closed the casing.

Open the casing carefully because there are WLAN cables that lead from the casing cover to the system and these may break if the casing is opened carelessly.

- ▶ Remove any connected wires which are in the way.

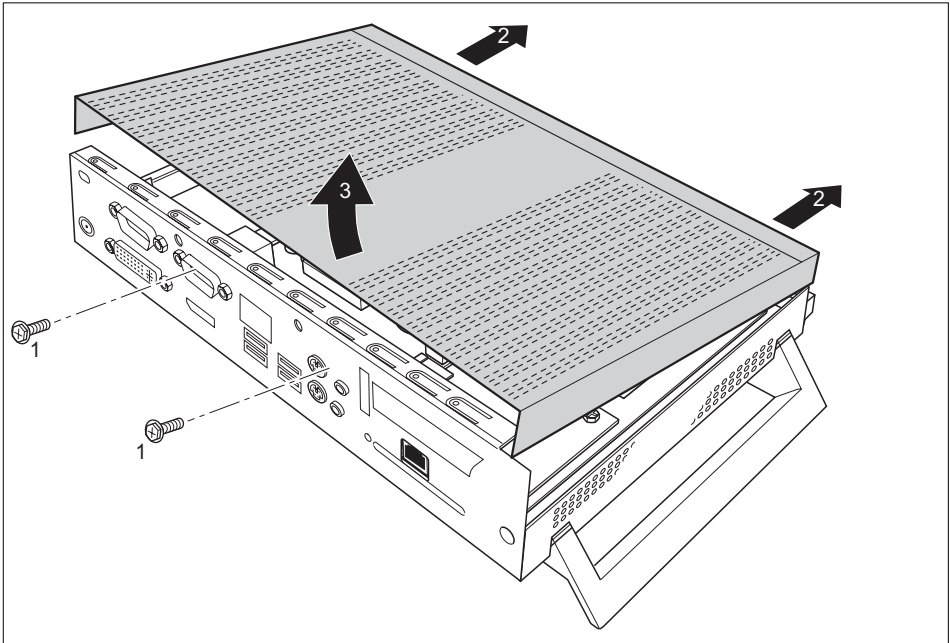

- ▶ Loosen the screws at the rear (1).
- ▶ Slide the casing cover in the direction of the arrow (2) and swing out the casing cover towards the front (3).

## Adding memory

If you want to remove or add memory, proceed as follows:



Please observe the safety information in chapter ["Important notes", Page 10](#).

Only use memory expansions for notebooks: 1 GByte and 2 GByte modules DDR3-1333 SO DIMM or DDR3-1600 SO DIMM.

Never use force when installing or removing a memory extension.

Make sure that foreign objects do not fall into the memory extension compartment.

Individual components (e.g. the processor heat sink) can become very hot during operation. We therefore recommend that you wait one hour after switching off the device before removing or installing the memory modules. Otherwise, there is a risk of suffering burns!

As some components are exposed that are sensitive to static electricity, please take note of chapter ["Information about boards", Page 31](#).

## Removing memory modules

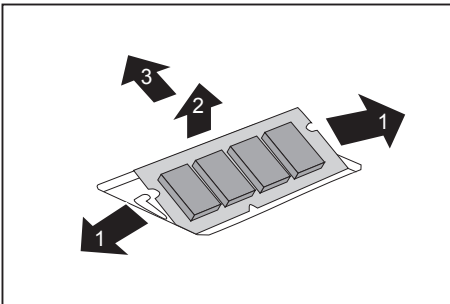

- ▶ Carefully push the two mounting clips outwards (1).
- ↳ The memory module snaps upwards (2).
- ▶ Pull the memory module out of its slot in the direction of the arrow (3).

## Installing a memory module

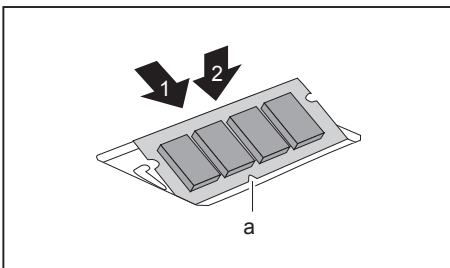

- ▶ Insert the memory module with the contacts and the recess (a) facing the slot (1).
- ▶ Carefully push the memory module downwards until you feel it click into place (2).

## Installing and removing the SmartCard reader (FUJITSU Thin Client FUTRO S920 only)



If you are also installing the optional loudspeaker, install the SmartCard reader before the loudspeaker.

### Installing the SmartCard reader

If not already installed, you can fit a SmartCard reader.

- ▶ Open the casing (see ["Opening the casing", Page 32](#)).
- ▶ If a PCIe board is installed, you must remove the cross piece and PCIe board (see ["Removing the board", Page 58](#)).

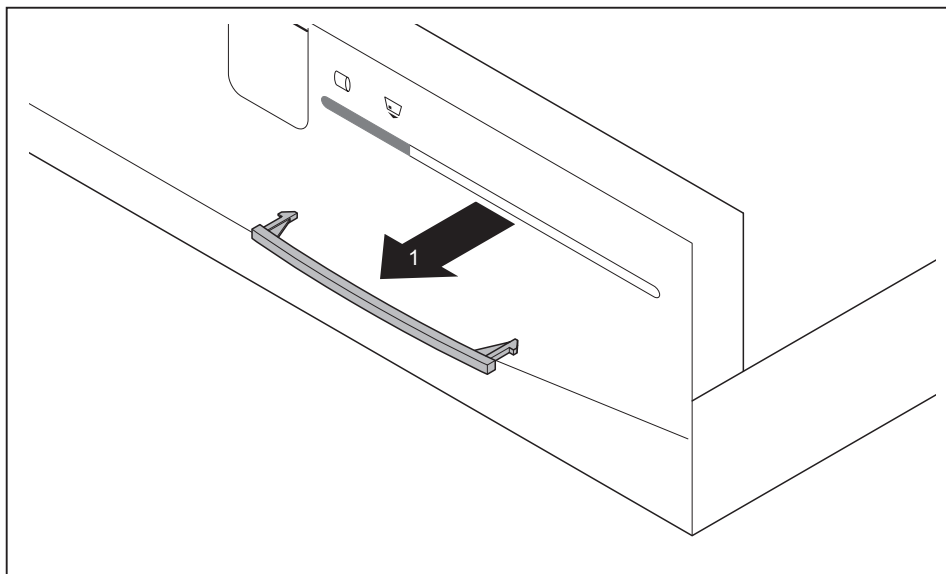

- ▶ Carefully remove the cover of the SmartCard reader bay from the casing cover (1).

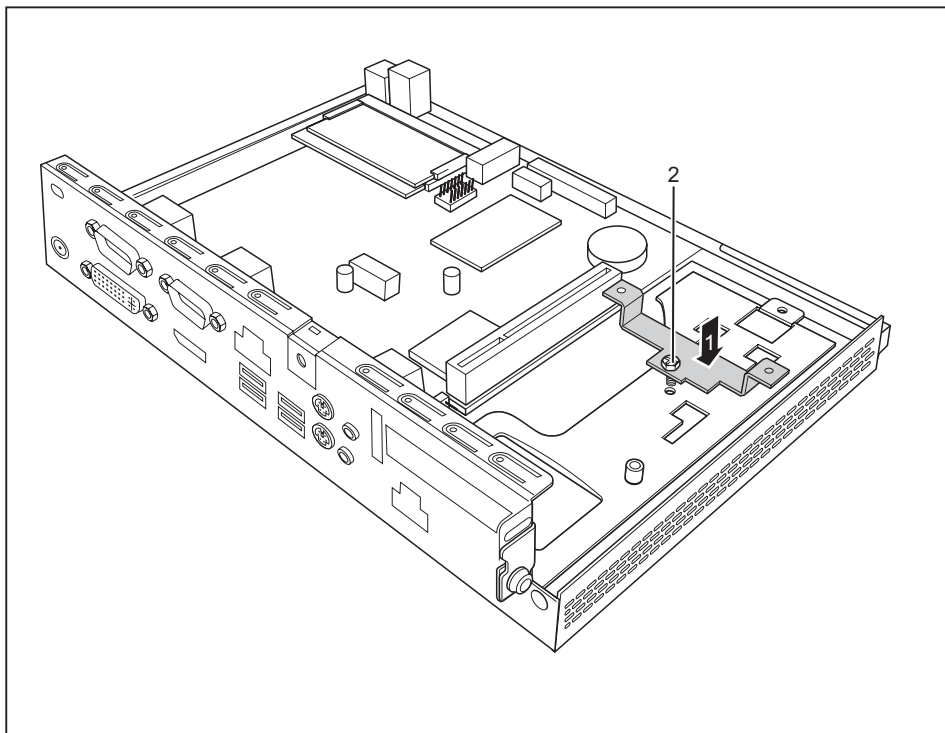

- ▶ Place the carrier for the SmartCard reader in the casing (1).
- ▶ Fasten the carrier with the screw (2).

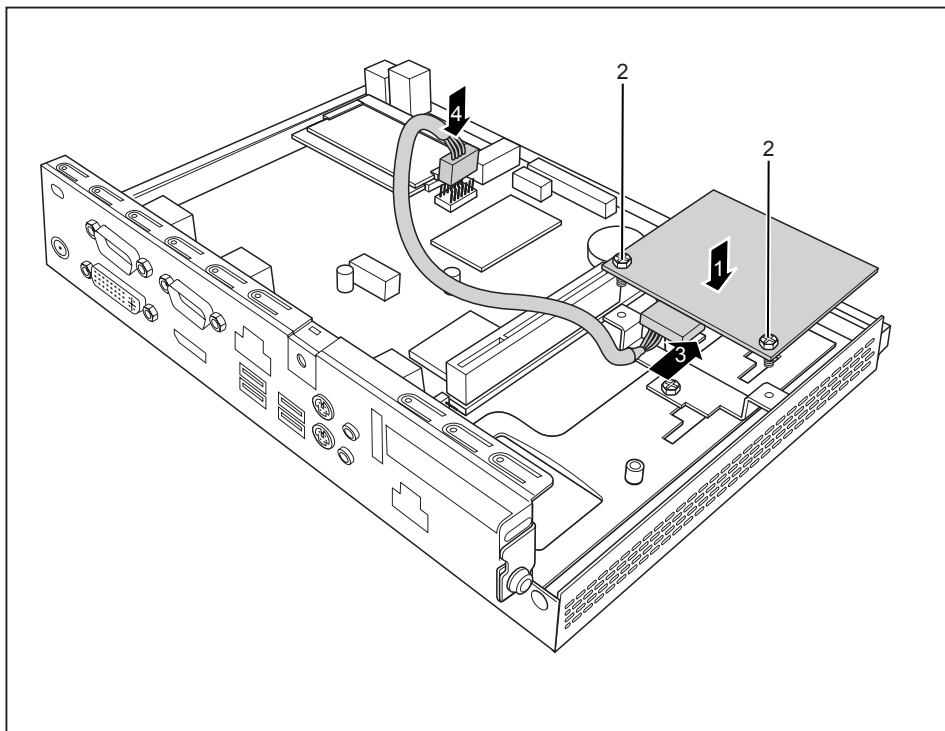

- ▶ Place the SmartCard reader on the carrier with the component side facing downwards, in the direction of the arrow (1).
- ▶ Fasten the SmartCard reader onto the carrier with the screws (2).
- ▶ Connect the cable to the SmartCard reader (3) and to the connector on the mainboard (4).
- ▶ When required, reinstall the cross piece and the PCIe board (see ["Installing the board", Page 56](#)).
- ▶ Close the casing (see ["Closing the casing", Page 60](#)).



Make sure that the cables are not trapped between the casing and the components.



## Removing the SmartCard reader

- ▶ Open the casing (see ["Opening the casing", Page 32](#)).
- ▶ If a PCIe board is installed, you must remove the cross piece and PCIe board (see ["Removing the board", Page 58](#)).

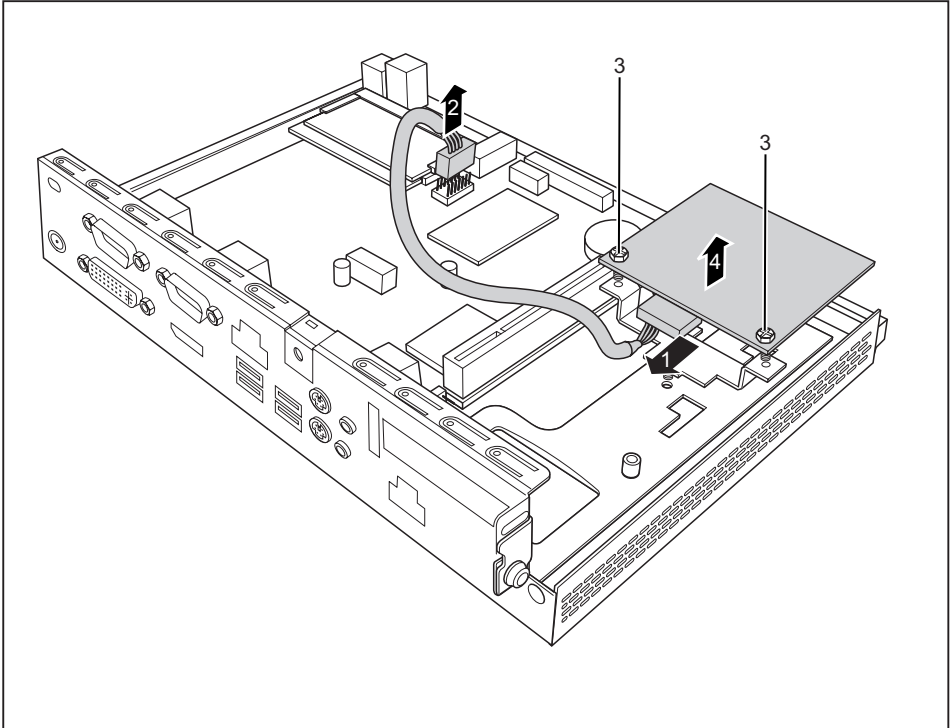

- ▶ Disconnect the cable from the SmartCard reader (1) and from the mainboard (2).
- ▶ Undo the screws (3).
- ▶ Lift the SmartCard reader from the carrier (4).
- ▶ When required, reinstall the cross piece and the PCIe board (see ["Installing the board", Page 56](#)).
- ▶ Close the casing (see ["Closing the casing", Page 60](#)).

**i**

Ensure that cables are not trapped between the casing and the components.

## Information about installing and removing a speaker (optional)

You can install an additional speaker in your device:

- For FUJITSU Thin Client FUTRO S720 / FUJITSU Thin Client FUTRO S920, see chapter "[Installing and removing a speaker: FUJITSU Thin Client FUTRO S720 / FUJITSU Thin Client FUTRO S920](#)", Page [39](#)
- For FUJITSU Desktop ESPRIMO A525-L, see chapter "[Installing and removing a speaker: FUJITSU Desktop ESPRIMO A525-L](#)", Page [41](#)

# Installing and removing a speaker: FUJITSU Thin Client FUTRO S720 / FUJITSU Thin Client FUTRO S920

## Installing the loudspeaker

**i**

The required hexagon head bolts are included in the delivery scope of the loudspeaker.

- ▶ Open the housing (see ["Opening the casing", Page 32](#)).
- ▶ If a PCIe board is installed, you must remove the cross piece and PCIe board (see ["Removing the board", Page 58](#)).

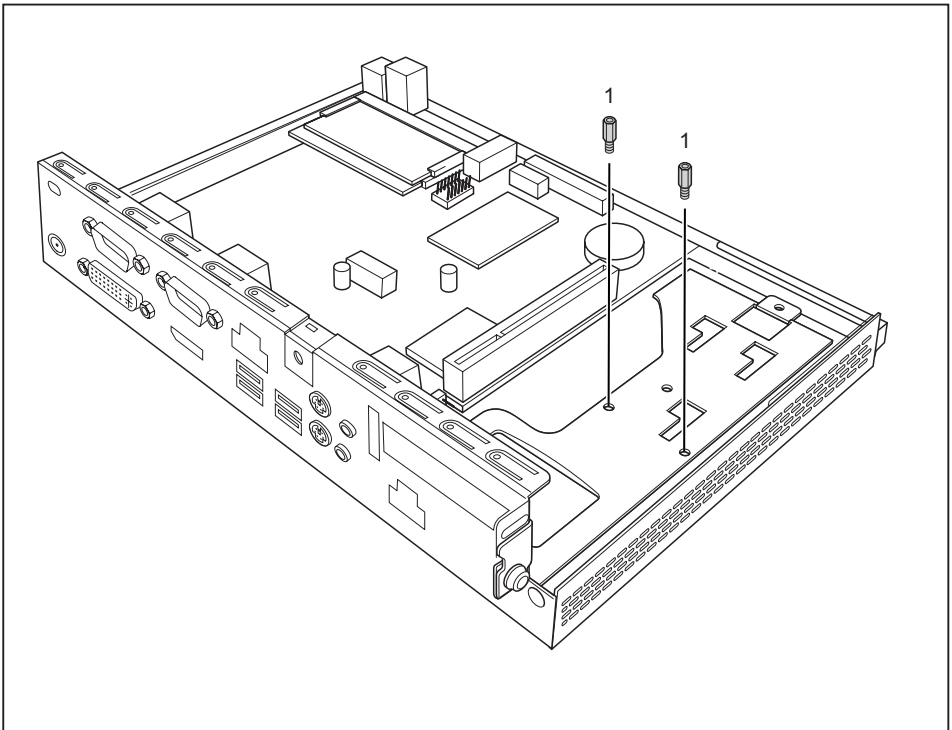

- ▶ Secure the hexagon head bolts provided into the screw holes (1).

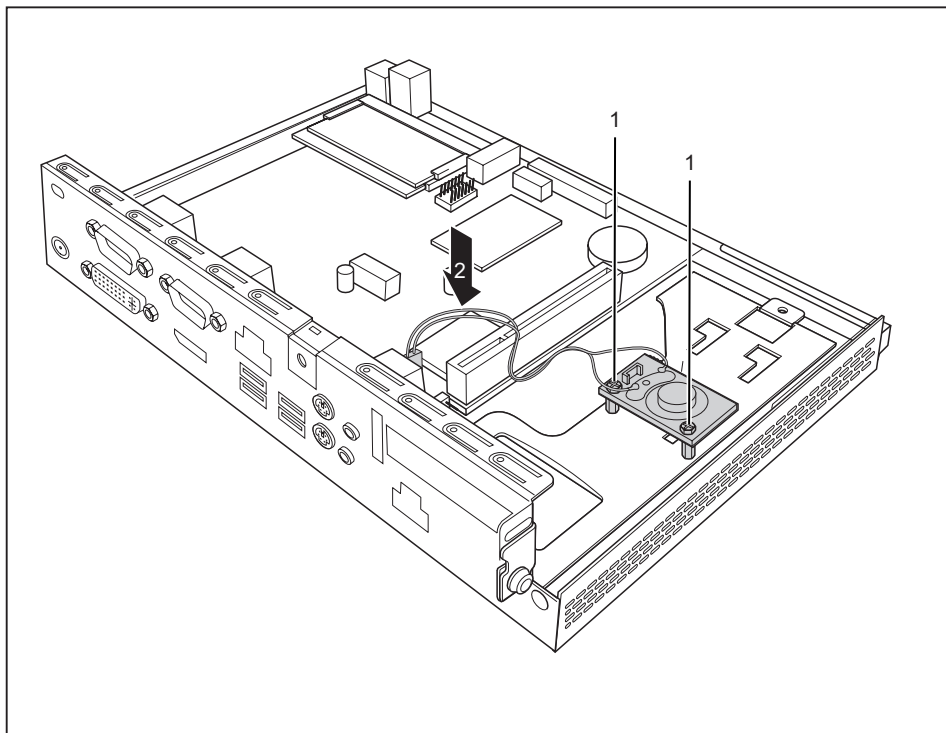

- ▶ Insert the loudspeaker into the housing as illustrated.
- ▶ Secure the loudspeaker with the screws (1).
- ▶ Connect the loudspeaker cable to the connector on the mainboard (2).
- ▶ When required, reinstall the cross piece and the PCIe board (see ["Installing the board", Page 56](#)).
- ▶ Close the housing (see ["Closing the casing", Page 60](#)).



Ensure that the cables are not trapped between the housing and the components.

## Removing the loudspeaker

- ▶ Open the housing (see ["Opening the casing", Page 32](#)).
- ▶ If a PCIe board is installed, you must remove the cross piece and PCIe board (see ["Removing the board", Page 58](#)).

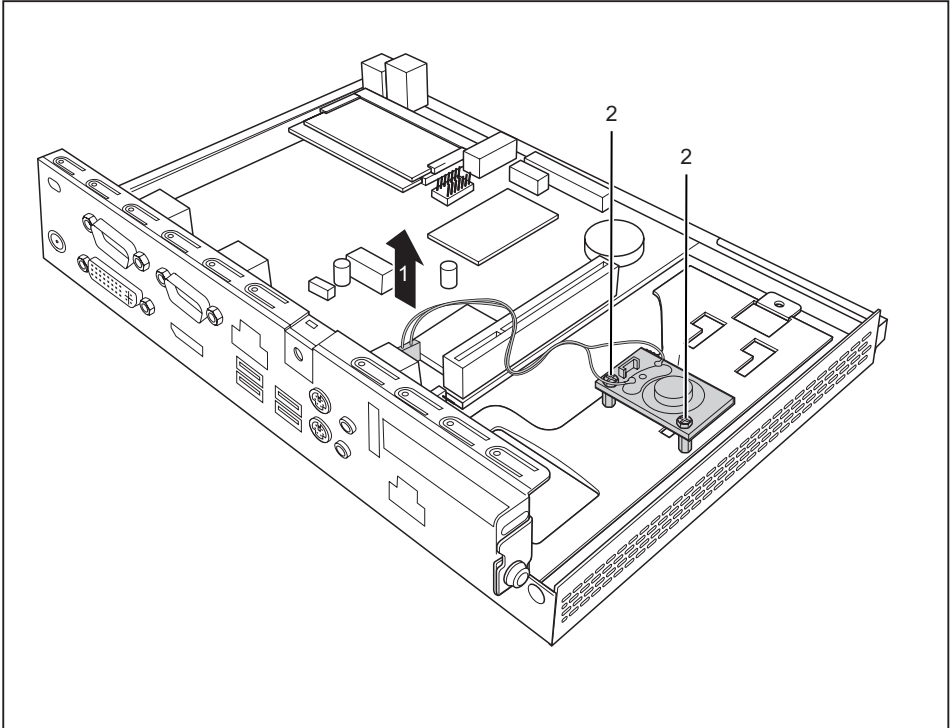

- ▶ Disconnect the loudspeaker cable from the mainboard (1).
- ▶ Undo the screws (2).
- ▶ Lift the loudspeaker out of the housing.
- ▶ When required, reinstall the cross piece and the PCIe board (see ["Installing the board", Page 56](#)).
- ▶ Close the housing (see ["Closing the casing", Page 60](#)).

## Installing and removing a speaker: FUJITSU Desktop ESPRIMO A525-L



Before installing a speaker in the FUJITSU Thin Client ESPRIMO A525-L, you must first remove the hard disk.

## Installing a speaker

### Removing a hard disk

- ▶ Open the housing (see ["Opening the casing", Page 32](#)).

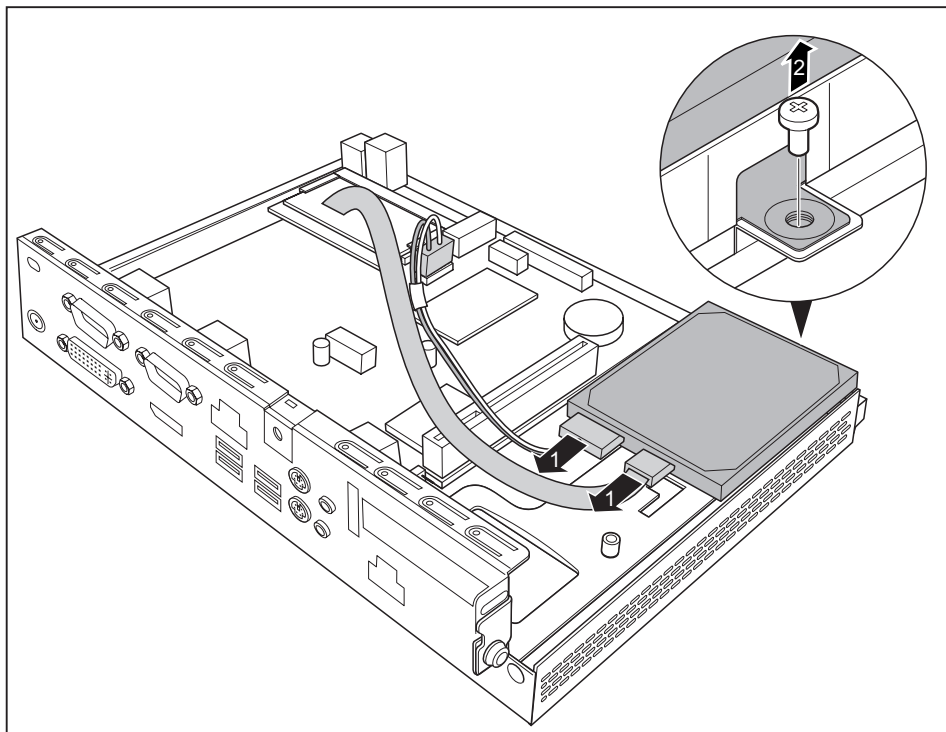

- ▶ Disconnect the cables from the hard disk (1).
- ▶ Undo the screw (2).

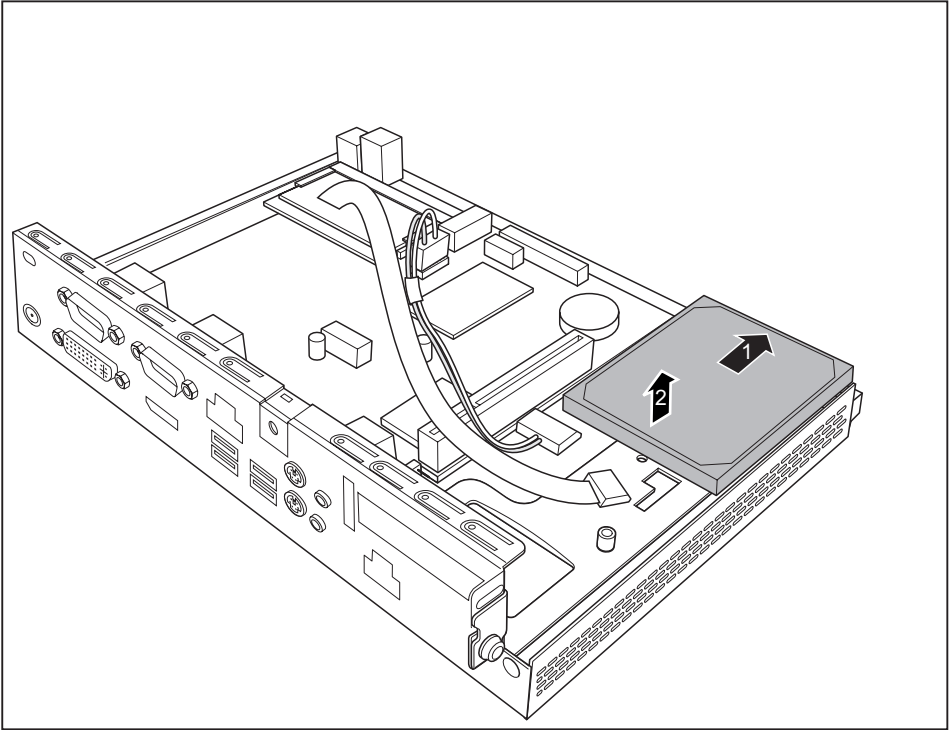

- ▶ Slide the hard disk in the direction of the arrow (1).
- ▶ Lift the hard disk out of the casing (2).

## Installing the loudspeaker



The required hexagon head bolts are included in the delivery scope of the loudspeaker.

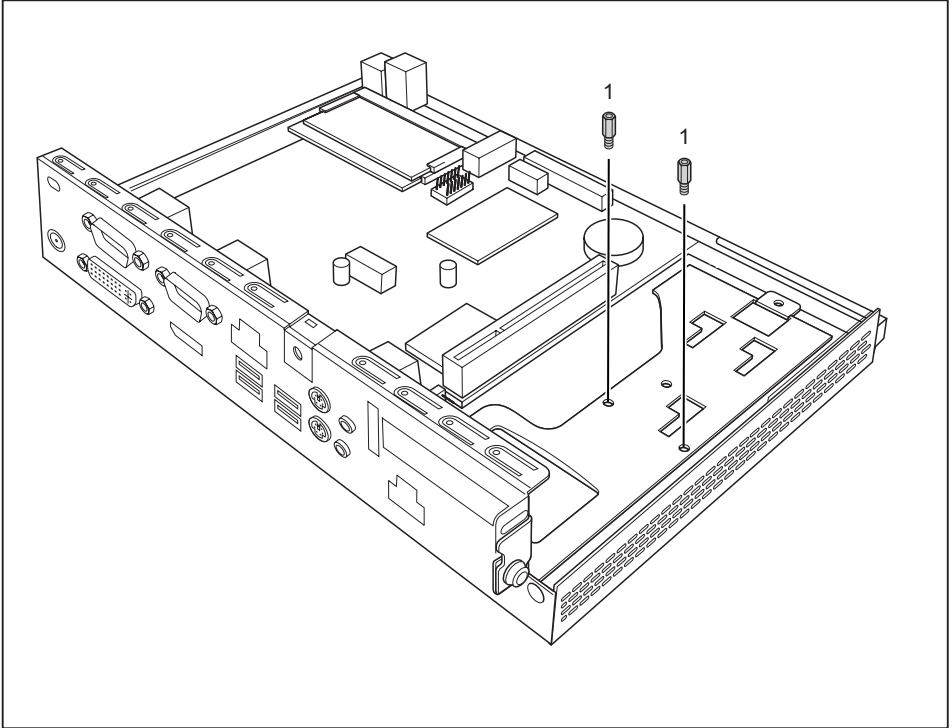

- ▶ Secure the hexagon head bolts provided into the screw holes (1).



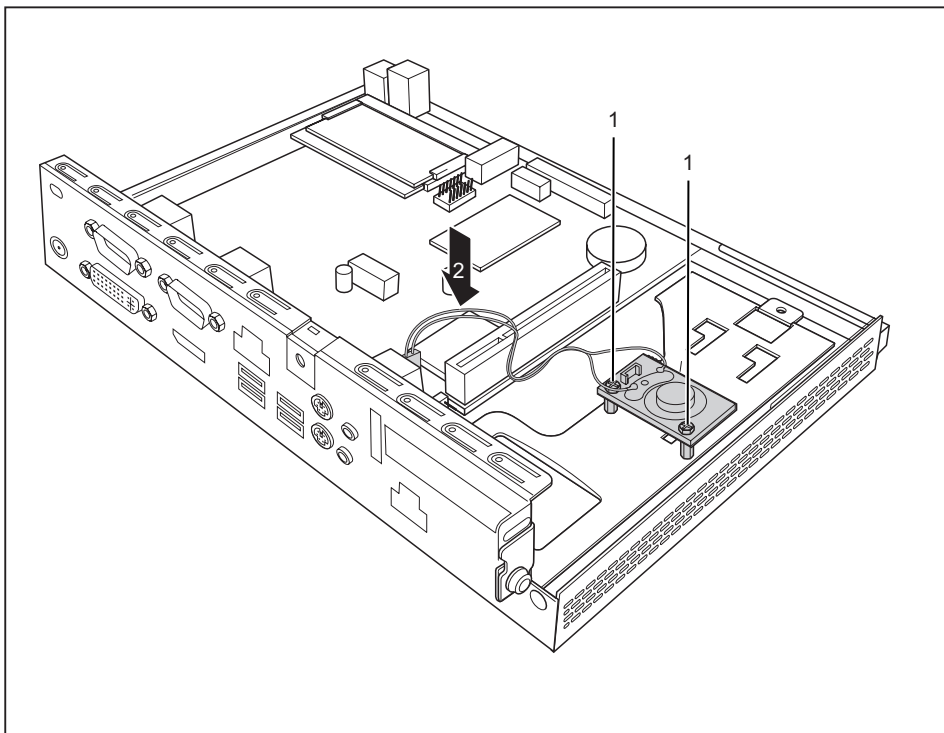

- ▶ Insert the loudspeaker into the housing as illustrated.
- ▶ Secure the loudspeaker with the screws (1).
- ▶ Connect the loudspeaker cable to the connector on the mainboard (2).

## Installing a hard disk

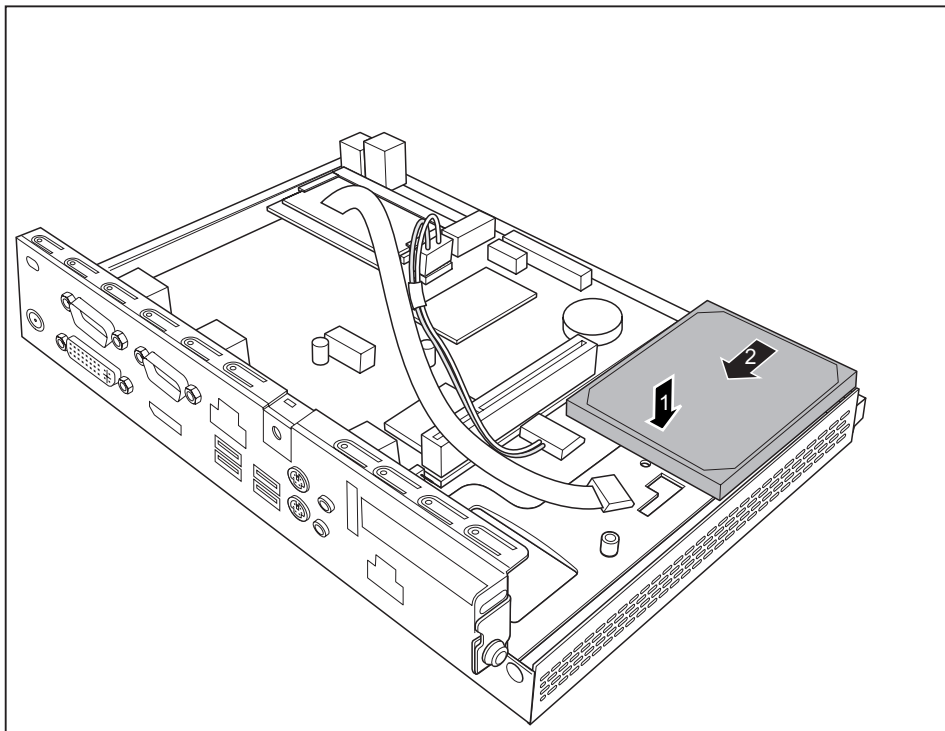

- ▶ Insert the hard disk into the casing (1).
- ▶ Slide the hard disk in the direction of the arrow (2).

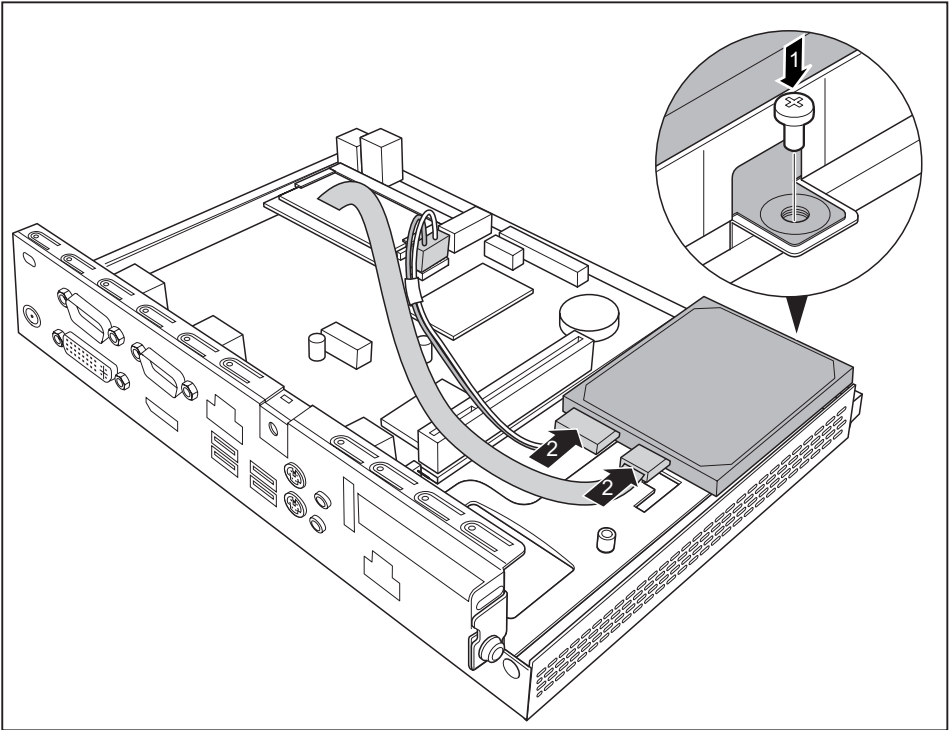

- ▶ Secure the hard disk with the screw (1).
- ▶ Connect the cables to the hard disk (2).
- ▶ Close the housing (see ["Closing the casing", Page 60](#)).

**i**

Make sure that the cables are not trapped between the casing and the components.

## Removing a speaker

### Removing a hard disk

- ▶ Open the housing (see ["Opening the casing", Page 32](#)).

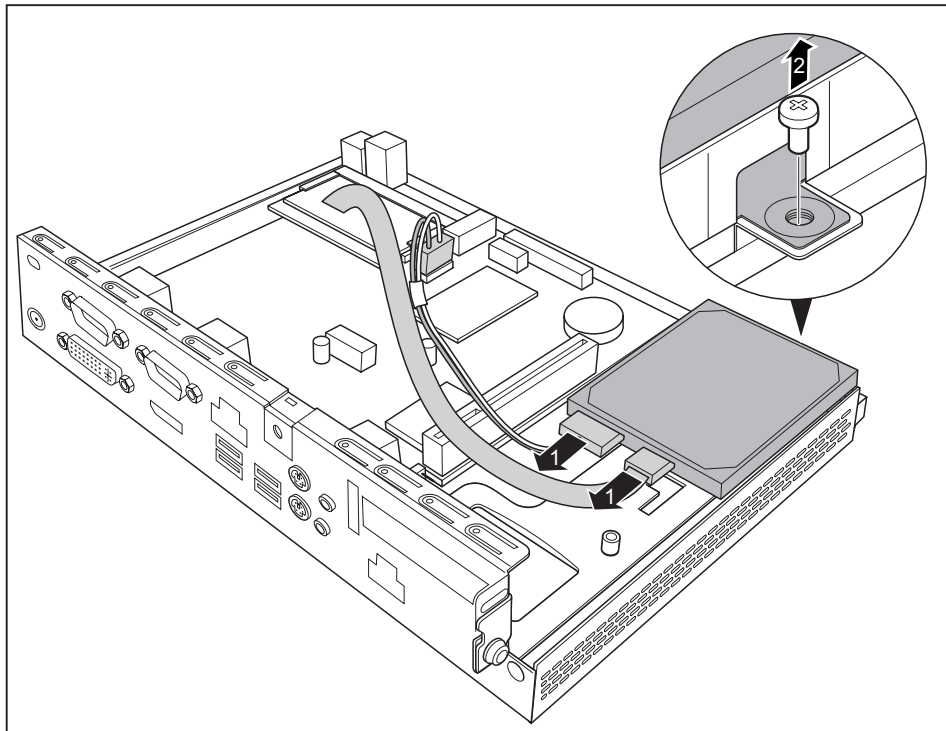

- ▶ Disconnect the cables from the hard disk (1).
- ▶ Undo the screw (2).

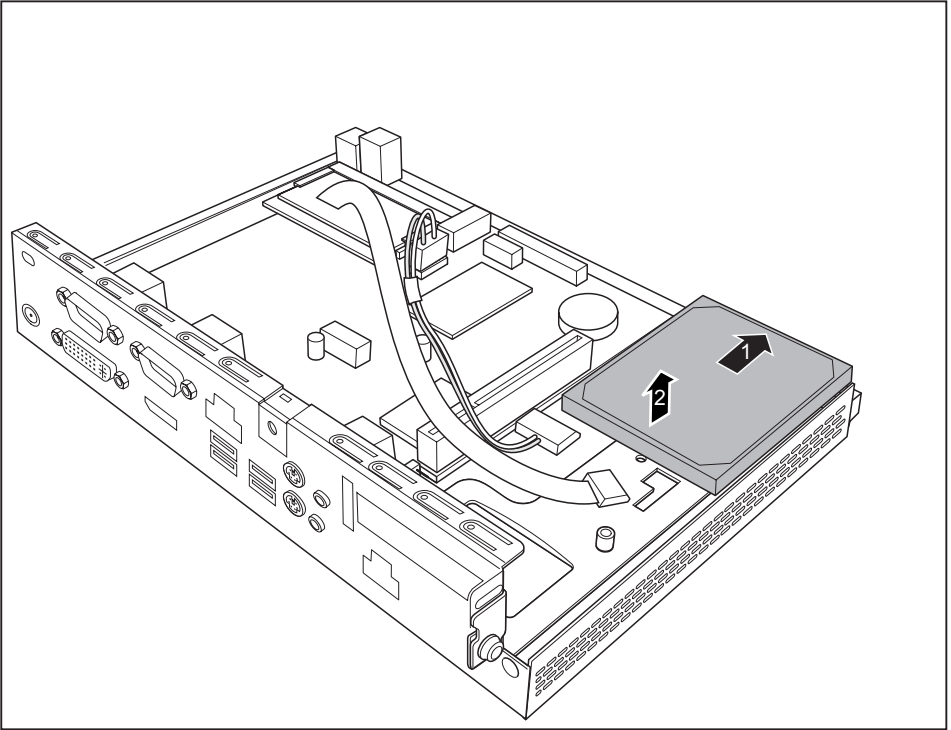

- ▶ Slide the hard disk in the direction of the arrow (1).
- ▶ Lift the hard disk out of the casing (2).

## Removing the loudspeaker

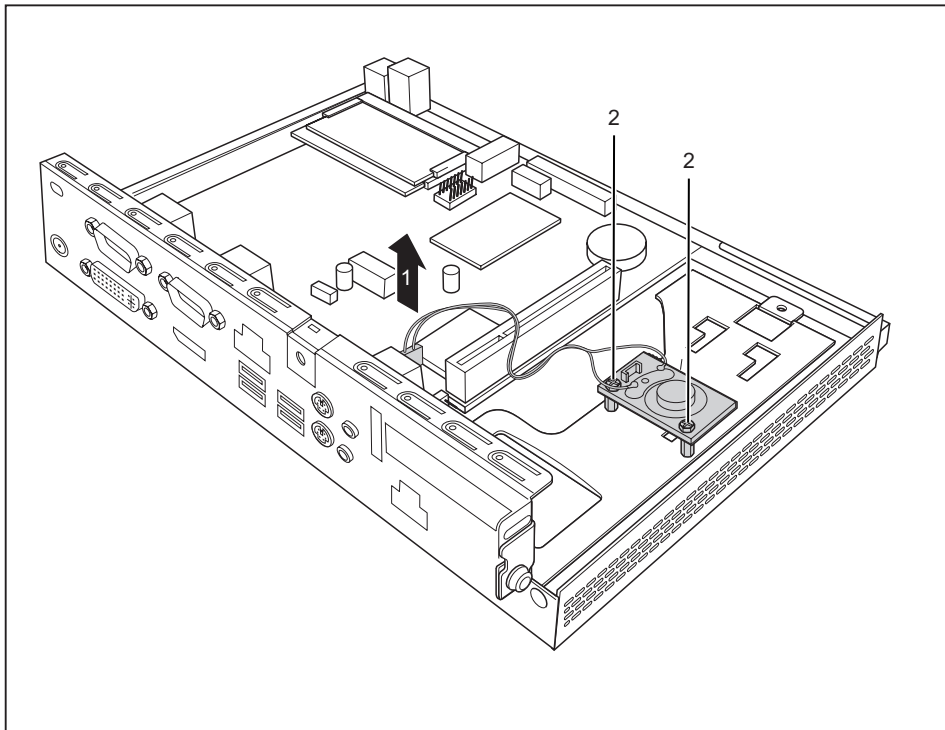

- ▶ Disconnect the loudspeaker cable from the mainboard (1).
- ▶ Undo the screws (2).
- ▶ Lift the loudspeaker out of the housing.

## Installing a hard disk

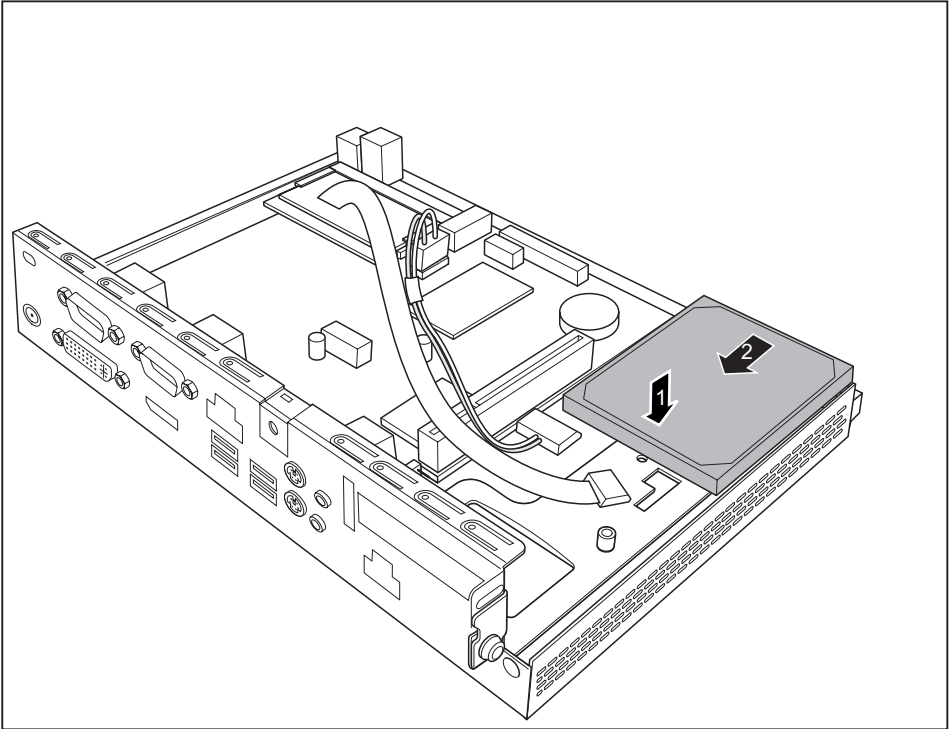

- ▶ Insert the hard disk into the casing (1).
- ▶ Slide the hard disk in the direction of the arrow (2).

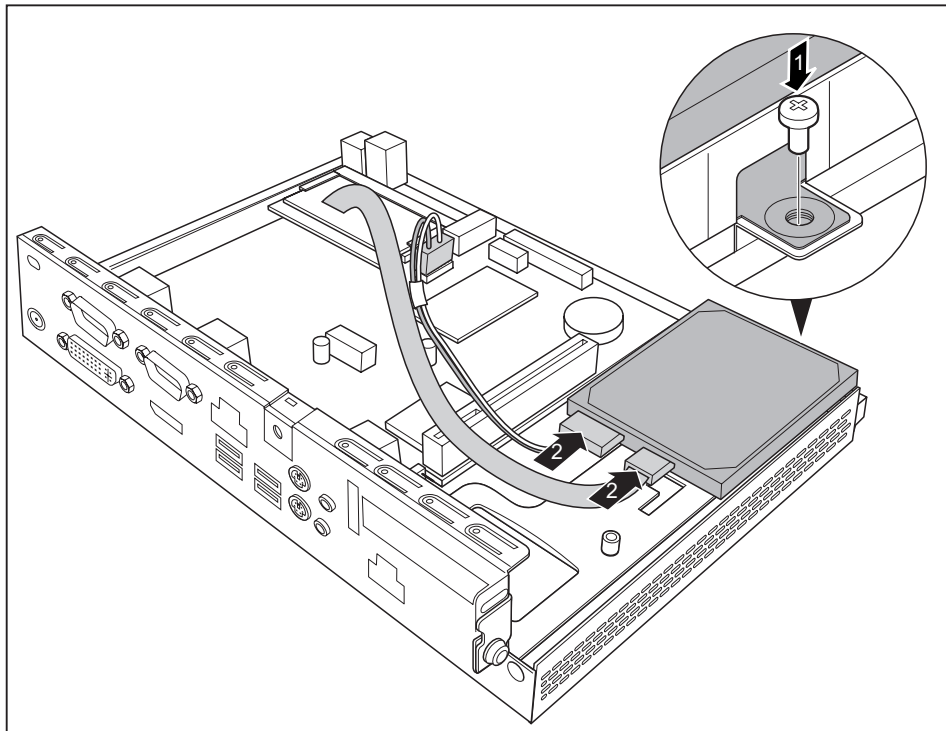

- ▶ Secure the hard disk with the screw (1).
- ▶ Connect the cables to the hard disk (2).
- ▶ Close the housing (see ["Closing the casing", Page 60](#)).



Make sure that the cables are not trapped between the casing and the components.



## Installing and removing a Power over Ethernet module (optional)



You can install an additional Power over Ethernet module in your device.

Before using the module for the first time, please observe the notes in chapter ["Getting started", Page 16](#).

If you are supplying the system with power via the PoE module, ensure that no additional power supply (mains adapter) is connected.

### Installing the Power over Ethernet module

- ▶ Open the casing (see ["Opening the casing", Page 32](#)).
- ▶ If a PCIe board is installed, you must remove the cross piece and PCIe board (see ["Removing the board", Page 58](#)).
- ▶ FUJITSU Desktop ESPRIMO A525-L: If a hard disk is installed, remove it (see ["Removing a hard disk", Page 42](#)).

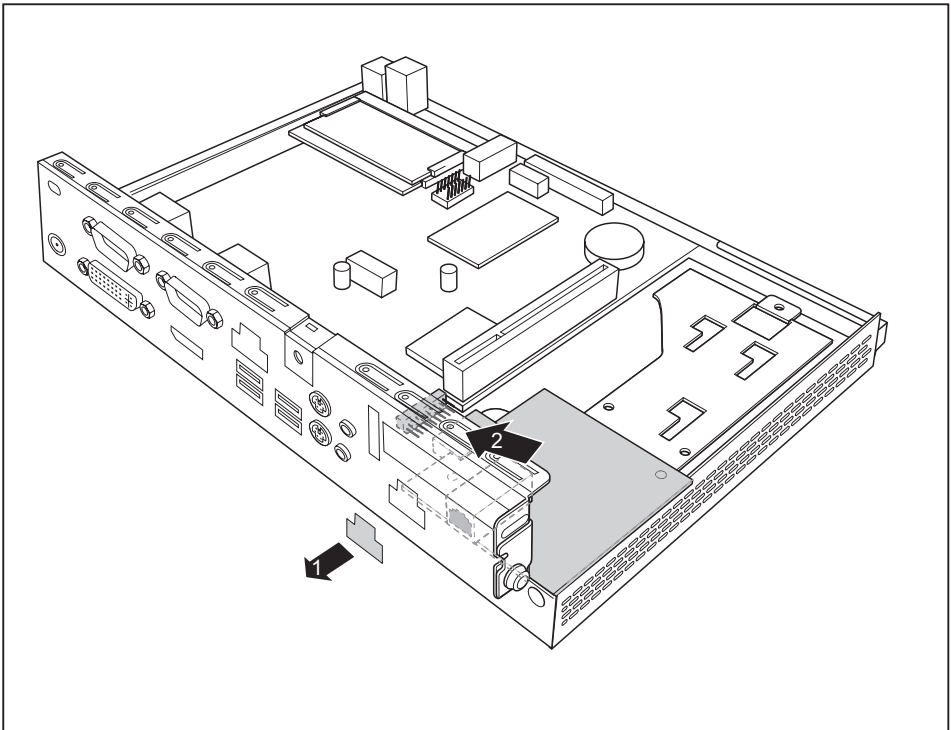

- ▶ Break the cover (1) out of the casing.
- ▶ Place the Power over Ethernet module in the casing with the component side facing upwards (2). Ensure that it engages in the slot.

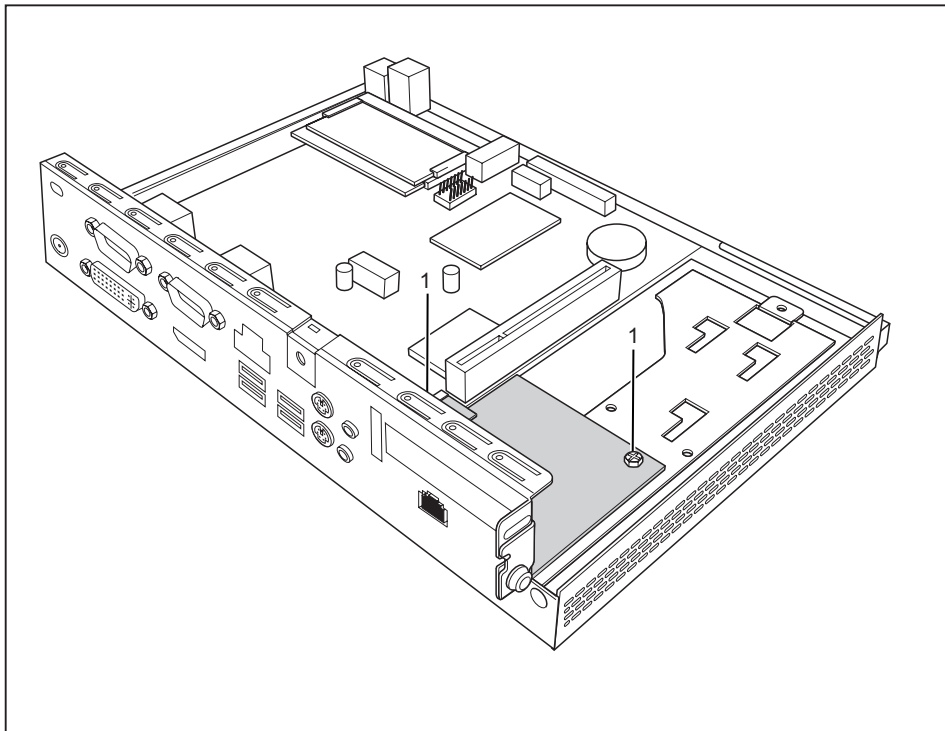

- ▶ Secure the Power over Ethernet module with the screws (1).
- ▶ FUJITSU Desktop ESPRIMO A525-L: When required, reinstall the hard disk (see ["Installing a hard disk", Page 46](#)).
- ▶ When required, reinstall the cross piece and the PCIe board (see ["Installing the board", Page 56](#)).
- ▶ Close the casing (see ["Closing the casing", Page 60](#)).



Make sure that the cables are not trapped between the casing and the components.

## Removing the Power over Ethernet module

- ▶ Open the casing (see ["Opening the casing", Page 32](#)).
- ▶ If a PCIe board is installed, you must remove the cross piece and PCIe board (see ["Removing the board", Page 58](#)).
- ▶ FUJITSU Desktop ESPRIMO A525-L: If a hard disk is installed, remove it (see ["Removing a hard disk", Page 42](#)).

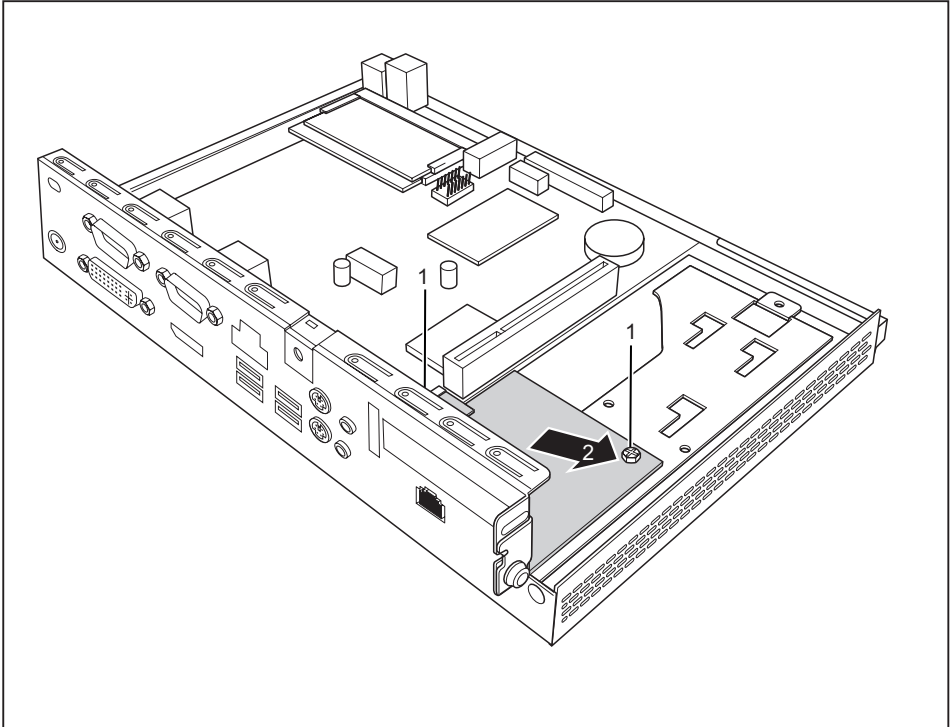

- ▶ Undo the screws (1).
- ▶ Pull the Power over Ethernet module in the direction of the arrow (2) out of the slot and lift it out of the casing.
- ▶ FUJITSU Desktop ESPRIMO A525-L: When required, reinstall the hard disk (see ["Installing a hard disk", Page 46](#)).
- ▶ When required, reinstall the cross piece and the PCIe board (see ["Installing the board", Page 56](#)).
- ▶ Close the casing (see ["Closing the casing", Page 60](#)).



Ensure that cables are not trapped between the casing and the components.

## Installing and removing a board



You can install various boards (e.g. a graphics card) in your device.

Before using a graphics card for the first time, please pay attention to the notes in chapter ["Important notes on preparing your FUTRO S920 for use with an external graphics card"](#), Page 11.

The installation and removal procedure is the same for all types of board. A PCIe board is shown below.

### Installing the board

You can only install boards with a maximum length of 170 mm.

- ▶ Enter the required settings for the board.
- ▶ Open the casing (see ["Opening the casing"](#), Page 32).

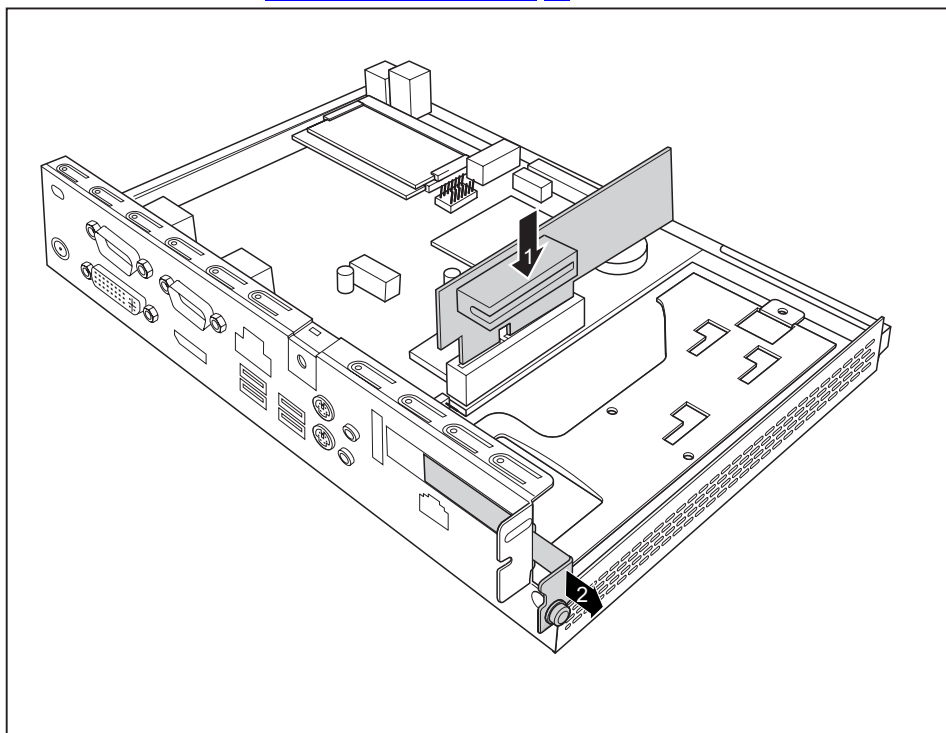

- ▶ Insert the riser card in its slot (1).
- ▶ Undo the screw (1) and remove the rear slot cover plate of the slot (2).



Do not throw away the rear slot cover plate. For cooling, protection against fire and in order to comply with EMC regulations, you must refit the cover plate if you remove the board.

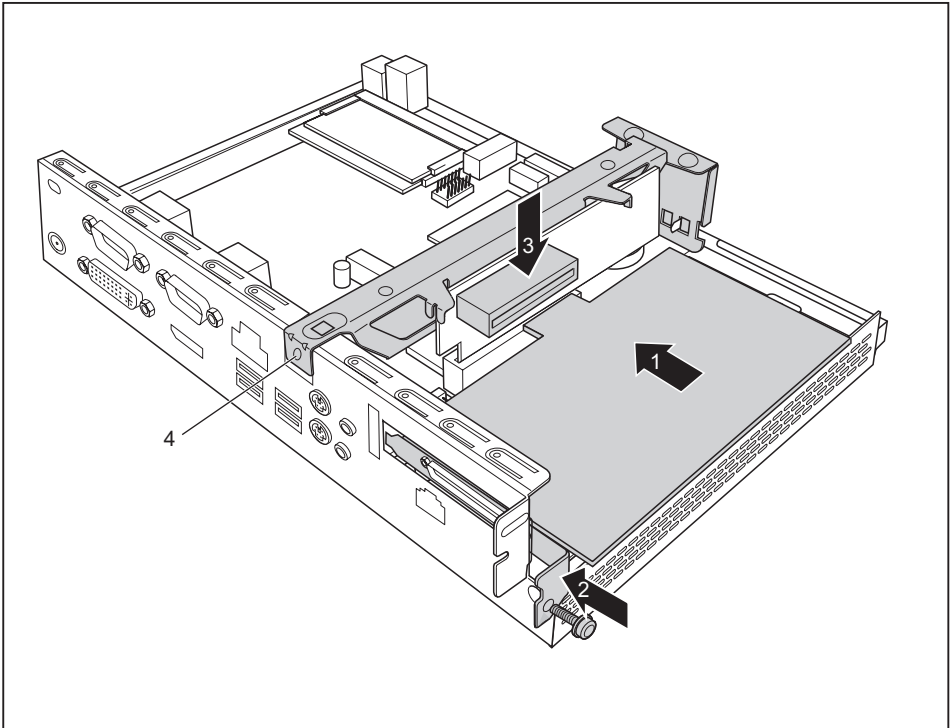

- ▶ Insert the board into the riser card (1).
- ▶ Fix the board with the screw (2).
- ▶ Install the cross piece (3).
- ▶ Secure the cross piece with the screw (4).
- ▶ Close the casing (see ["Closing the casing", Page 60](#)).

## Removing the board

- ▶ Open the casing (see ["Opening the casing", Page 32](#)).

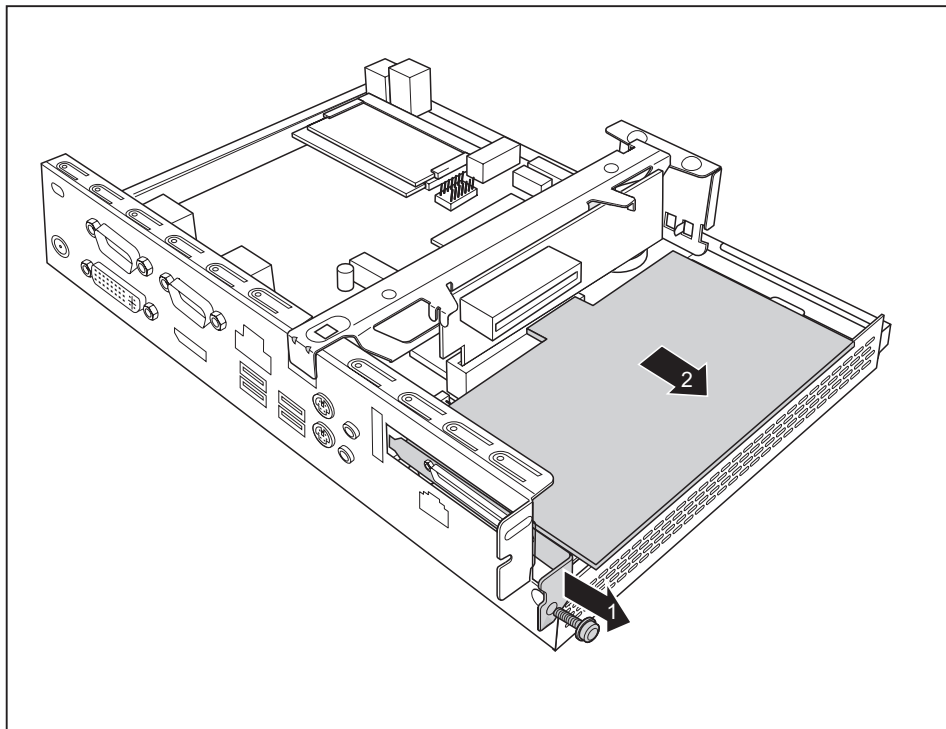

- ▶ Loosen the screw (1).
- ▶ Remove the board from the riser card (2).



You must reinstall the rear slot cover plate due to cooling, fire protection and the EMC regulations (regulations on electromagnetic compatibility) to be complied with.

- ▶ Reinstall the rear slot cover plate by inserting it in the installation slot from the inside and securing it with the screw.
- ▶ Close the casing (see ["Closing the casing", Page 60](#)).

## Replacing the lithium battery

In order to permanently save the system information, a lithium battery is installed to provide the CMOS-memory with a current. A corresponding error message notifies the user when the charge is too low or the battery is empty. The lithium battery must then be replaced.



Incorrect replacement of the lithium battery may lead to a risk of explosion!

The lithium battery may be replaced only with an identical battery or with a type recommended by the manufacturer.

Do not dispose of lithium batteries with household waste. They must be disposed of in accordance with local regulations concerning special waste.

Make sure that you observe the correct polarity when replacing the lithium battery. The plus pole must be on the top!

The lithium battery holder exists in different designs that function in the same way.

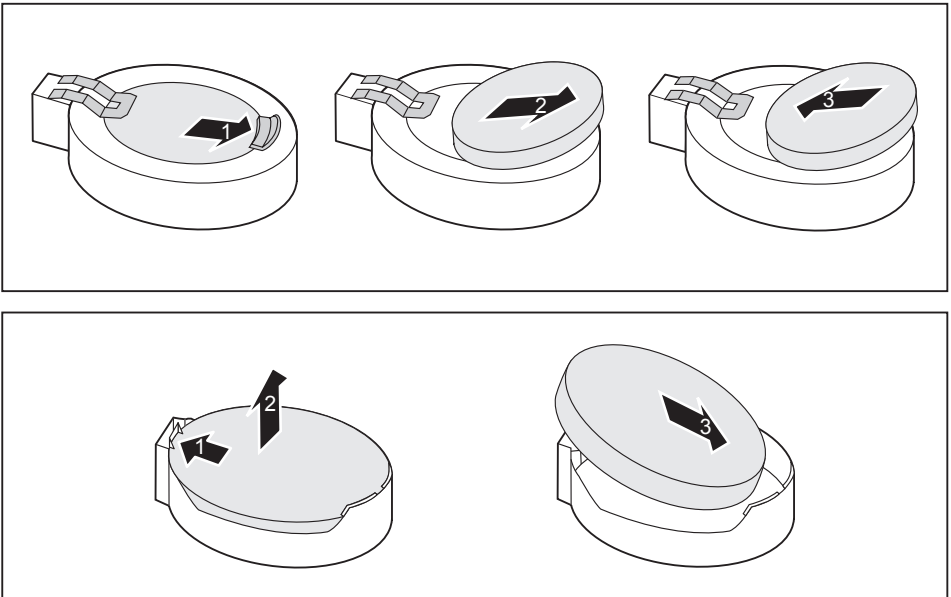

- ▶ Press the catch in the direction of the arrow (1).
- ↳ The battery jumps out of the holder slightly.
- ▶ Remove the battery (2).
- ▶ Push the new lithium battery of the identical type into the holder (3) and press it down until it engages.

## Closing the casing

- ▶ Replace the casing cover on the device and push it backwards.
- ▶ Secure the casing cover with the two screws on the rear of the device.



Make sure that the cables are not trapped between the casing and the components.

- ▶ Connect all the cables removed before.



# Technical data

## FUTRO/ESPRIMO

Electrical data	FUTRO S720	FUTRO S920	ESPRIMO A525-L
Processor:	AMD G Series GX-217GA (1,50 GHz, Dual Core, 1 MB, AMD Radeon™ HD 8280E) /  AMD G Series GX-222GC (2,20 GHz, Dual Core, 1 MB, AMD Radeon™ R5E)	AMD G Series GX-415GA (1,50 GHz, Quad Core, 2 MB, AMD Radeon™ HD 8330E) /  AMD G Series GX-424CC (2,40 GHz, Quad Core, 2 MB, AMD Radeon™ R5E) /  AMD G Series GX-222GC (2,20 GHz, Dual Core, 1 MB, AMD Radeon™ R5E)	AMD G Series GX-217GA (1,50 GHz, Dual Core, 1 MB, AMD Radeon™ HD 8280E) /  AMD G Series GX-222GC (2,20 GHz, Dual Core, 1 MB, AMD Radeon™ R5E)
Rated voltage:	19 - 20 V		
Max. rated current:	2.0 A or 3.25 A	2.0 A or 3.25 A	2 A
<b>Dimensions (vertical operating position)</b>			
Width x Depth x Height (with foot):	97 mm x 195 mm x 267 mm / 3.82 inches x 7.68 inches x 10.51 inches		
Width x Depth x Height (without foot):	52 mm x 195 mm x 250 mm / 2.05 inches x 7.68 inches x 9.84 inches		
<b>Dimensions (horizontal operating position, without WLAN)</b>			
Width x Depth x Height (with foot):	295 mm x 195 mm x 72 mm / 11.61 inches x 7.68 inches x 2.63 inches		
Width x Depth x Height (without foot):	250 mm x 195 mm x 57 mm / 9.84 inches x 7.68 inches x 2.05 inches		
<b>Weight</b>			
in basic configuration:	approx. 1.2 kg / 2.64 lbs	approx. 1.3 kg / 2.87 lbs	approx. 1.4 kg / 3.08 lbs

## Technical data

---

Environmental conditions	
Temperature:	
• Operation	15 °C .... 35 °C / 59 °F ... 95 °F
• Transportation	-25 °C .... 60 °C / -13 °F ... 140 °F
Clearance required to ensure adequate ventilation:	Minimum of 200 mm / 7.87 inches on all sides



Condensation must be avoided during operation.

## AC adapter

Electrical data	
Rated voltage:	100 - 240 V
Max. rated current:	1.2 A (40 W) or 1.5 A (65 W)
Rated frequency:	50 - 60 Hz



Only the following adapters with Limited Power Source may be used:

- 40W: S26113-E578-V55-01 Model: ADP-40PH AD
- 65W: S26113-E557-V55-03 Model: ADP-65JH AD

# Index

## A

- Audio input 21
  - line in 7
- Audio output 21
  - line out 6
  - Line Out 7

## B

- Base feet 16, 19
- Battery 59
- BIOS-Setup
  - opening 27
- Board,
  - installing 56
  - removing 58

## C

- Casing
  - closing 60
- Casing cover 60
- Casing,
  - opening 32
- Components
  - installing/removing 29
- Connecting a PS/2 keyboard 22
- Connecting,
  - keyboard 22
  - mouse 22
  - PS/2 keyboard 22
  - PS/2 mouse 22
  - USB keyboard 22

## D

- Data protection 7
- DC input connector
  - DC IN 7
- Device
  - Ports 21
- Device drivers,
  - serial interface 23
- Device,
  - opening 32
  - switching off 27
  - switching on 25
  - transporting 12
  - upgrades 29
- Devices,
  - connecting 23

- DisplayPort 21
- Disposal 13
- Drivers & Utilities DVD 13

## E

- Energy saving 13
- External devices
  - Ports 21
- External devices,
  - connecting 23

## F

- Flash memory access 6

## G

- Getting started 16

## H

- Hard disk
  - removing 42, 48
- Headphone port 6
- Headphones 21
  - connecting 24
- Horizontal operating position 19

## I

- Important notes 10
- Installation opening
  - for modules 7

## K

- Keyboard port 21
- Keyboard,
  - connecting 22
  - port 22

## L

- LAN 24
- LAN port 21
- LAN socket 7
- Line in 21
- Line out 21
- Line-out devices
  - connecting 24
- Lithium battery,
  - replacing 59

Loudspeaker  
installing 39, 44  
removing 41, 46, 50–51

## M

Main memory  
see Adding memory 33

Memory expansion  
installing 33  
removing 33

Memory module  
important notes 33  
installing 33  
removing 33

Microphone  
connecting 24

Microphone port 6, 21

Monitor port 7, 21

Monitor,  
Connecting 22  
switching off 27  
switching on 25

Mouse port 21

Mouse,  
connecting 22

## N

Note  
safety 10

Notes  
important 10

## O

Off switch 6

On switch 6

Operating position, horizontal 19

Operating position, vertical 16

## P

PCI slot 7

PCIe slot 7

Ports 6, 21

Power cable  
connection 24

Power over Ethernet module,  
installing 53  
removing 55

Power-on indicator 6

Preparing for operation 24

Property protection 7

Protection, property and data 7

PS/2 keyboard port 7

PS/2 mouse port 7, 21

PS/2 mouse,  
connecting 22  
port 22

PXE system boot 27

## R

Recycling 13

Removing memory  
see Adding memory 33

Replacing,  
lithium battery 59

Replacing, lithium battery 59

Retransportation 12

## S

Safety notes 10

Security Lock  
Security Lock device 7

Serial interface 23

Serial interface,  
connecting devices 23  
settings 23

Serial port 7, 21

Servicing 29

Side cover 16

SmartCard reader

indicator 6

installing 34

removing 37

System expansion 29, 33  
see Adding memory 33

System unit, see Device 12

## T

Technical data 61

Transportation 12

## U

Universal Serial Bus 21

Upgrades,  
device 29

USB  
ports 6

USB devices,  
connecting 23

USB port 22

USB port,  
  connecting devices 23  
  connecting keyboard 22  
  connecting the mouse 22  
USB ports 7  
User Documentation DVD 13

**V**  
Vertical operating position 16